

INCLUDING
*Communication
Engineering*
and
*TV & RADIO
ENGINEERING*

RADIO-ELECTRONIC *Engineering* SECTION

Reg. U. S. Pat. Off.

RADIO & TELEVISION NEWS

JUNE, 1954

MICROWAVES IN SULPHUR MINING
7

VERSATILE TRANSISTOR TESTER
10

EQUIPMENT COMPLEXITY
AND TUBE RELIABILITY
12

TIME-PROPORTIONAL
ELECTRONIC THERMOSTAT
15

POWER SWEEP GENERATOR FOR U.H.F.
16

AUTOMATIC DUAL AM-FM MONITOR
20

RADIO IN MATERIAL HANDLING
36

DEPARTMENTS

COMMUNICATION REVIEW	22
NEW PRODUCTS	24
TECHNICAL BOOKS	26
NEWS BRIEFS	28
NEW LITERATURE	30
TV-AM-FM PRODUCTION	30
PERSONALS	32
NEW TUBES	34
CALENDAR	40

In this scene from Raytheon's new color movie "Ready for Sea," which features dramatic phases in the design, production and testing of the Model 1500 "Mariners Pathfinder" radar, the antenna and transmitter-receiver unit is shown being lowered into a testing tank.

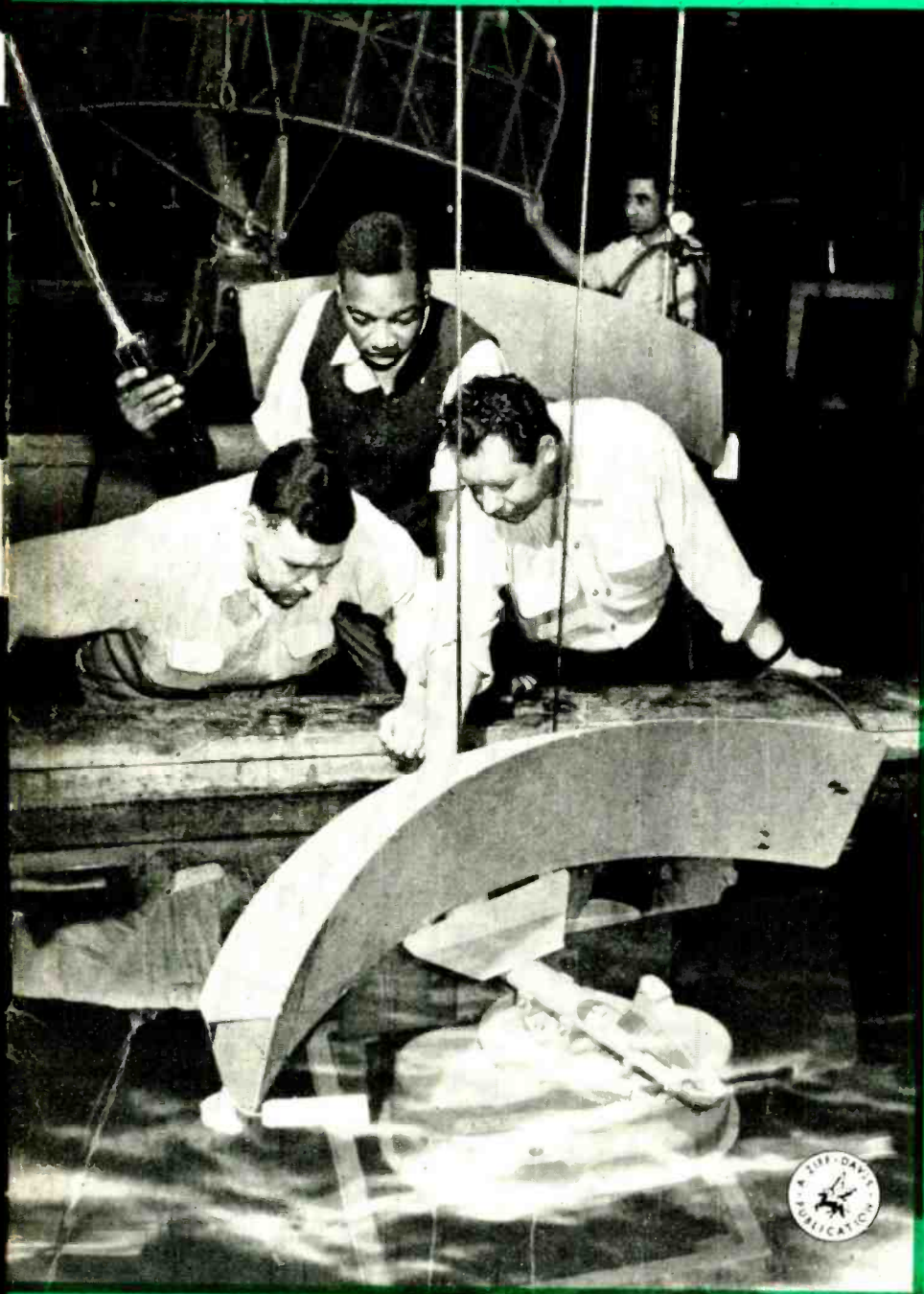

HERMETICALLY SEALED PULSE TRANSFORMERS

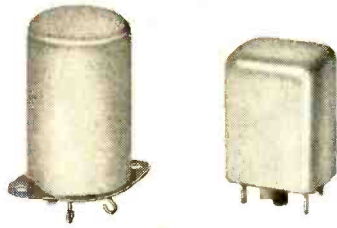

RCOF CASE
1 25/64 X 61/64"

SM CASE
11/16 X 1/2"

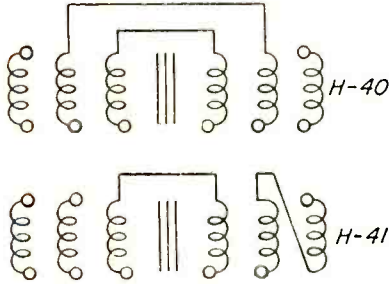

Because of the wide variety of blocking oscillator, interstage, and modulator pulse applications, the bulk of UTC pulse transformers are designed to customer's specifications. Through versatile design, however, the stock hermetic MIL-T-27 pulse transformers listed below take care of most low level applications. Wide ranges of pulse duration, loading, and level are obtainable by variations in the manner of connecting the balanced coil structure windings as shown in the engineering sheet accompanying each unit.

The H-40 and H-41 units employ identical windings suitable for different applications because of the manner in which the windings are brought out to the terminals. Pulse widths from .1 to 5 microseconds are realized with excellent fidelity. H-42 and H-43 are highly miniaturized units. They incorporate three equal windings capable of being inter-connected for wide versatility in blocking oscillator, interstage, and impedance matching service.

Type No.	Description*	Pulse Width Microsec.	Ins. Test Volts RMS	Case
H-40	Two 250 ohm windings . . . two 1000 ohm windings	.1 to 5	1000	RCOF
H-41	Two 250 ohm windings . . . two 1000 ohm windings	.1 to 5	1000	RCOF
H-42	Three 250 ohm windings	.15 to .75	500	SM**
H-43	Three 500 ohm windings	.5 to 2	500	SM**

* Impedances shown are nominal, subject to wide variation with application.
**Mtg. screw is centered on large side of case.



for SPECIAL APPLICATIONS

SERVO MOTOR MAGNETIC AMPLIFIERS

The MAT 1-4 Magnetic Amplifiers are exceptionally stable units designed for the control of 2 phase 400 cycle servo motors. They are compact . . . hermetically sealed . . . magnetically shielded . . . meet MIL-T-27 . . . high input impedance . . . high damping . . . high gain. The output is sinusoidal, amplitude variable, and phase reversible. Control is provided by a dual triode such as a 12AU7 operating with a plate voltage of 115 volts, 400 cycles, or higher. The signal to the triode grids can be polarity reversible DC or phase reversible 400 cycles. Power gain of the MAGNETIC STRUCTURE is approximately 40 . . . response time approximately 7.5 milliseconds . . . maximum null voltage 3V. RMS.

For AC signal control, the circuit of Figure 1 is employed. For DC signal control, Figure 2 applies. Figure 3 shows the use of a power transformer (MAT-5) which provides higher plate voltages and eliminates the input transformer (MAT-6). The typical response curve of Figure 4 applies to all units, the larger units feeding heavier loads.

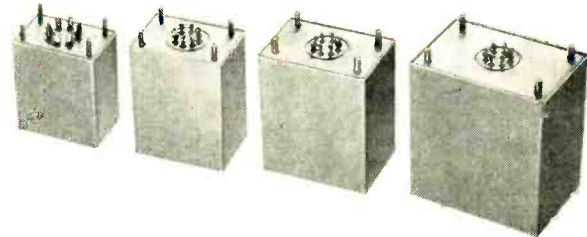

TYPE NO.	MAT-1	MAT-2	MAT-3	MAT-4
230 Volt Supply				
Power output	4 W.	8 W.	11 W.	18 W.
RL, ohms	3300	1600	1200	720
CL, mfd.	.2	.3	.5	.7
115 Volt Supply				
Power output	2 W.	4 W.	6 W.	9 W.
RL, ohms	6500	3300	2200	1450
CL, mfd.	.13	.2	.3	.45
Reson. Freq.	40 cyc.	35 cyc.	35 cyc.	20 cyc.
Log-Decr.	.18	.23	.03	.65
Cont. Wdg. Res.	6200 ohms	8450 ohms	4750 ohms	5650 ohms
Case				
Length, in.	1 1/4	1 1/2	1 3/4	2 1/8
Width, in.	1 1/16	2 1/8	2 1/2	3 1/8
Height, in.	2 3/16	2 3/4	2 1/16	3 3/8
Unit Weight, lbs.	.67	1.1	1.7	2.75
MAT-5	115V. 400 cyc. to 460 VCT; provides 230V. 48 MA DC or 460V. 24 MA DC. RC-37 Case . . . 1 3/8 x 1 3/8 x 1 1/8 . . . 1/8 mtg. holes 1 1/8 x 1 1/8 . . . 6 oz.			
MAT-6	Input . . . 10,000 ohms pri . . . 1:15 C.T. ratio . . . phase shift under 1° . . . RCOF case.			

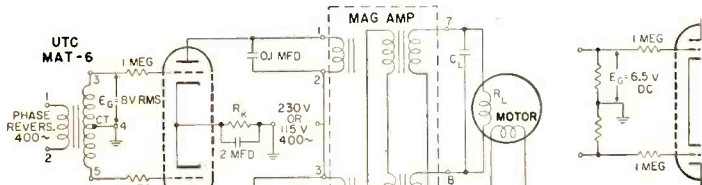

FIG #1
PUSH-PULL GRIDS-PARALLEL PLATES

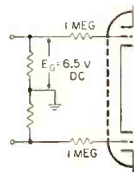

FIG #2
GRID CIRCUIT MODIFICATION FOR DC INPUT

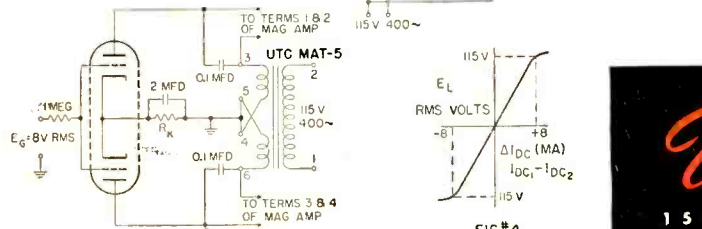

FIG #3
PARALLEL GRIDS-PUSH-PULL PLATES

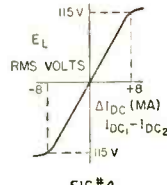
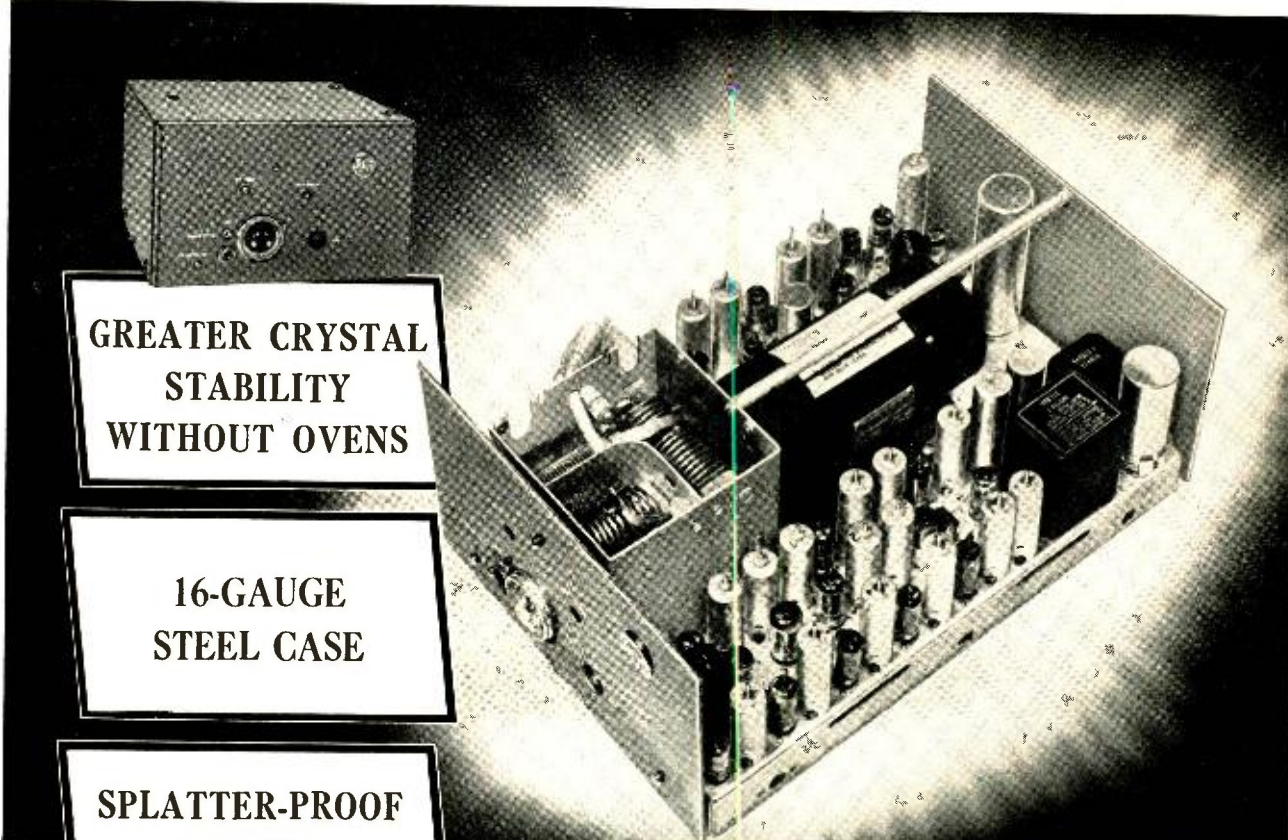

FIG #4

United Transformer Co.
150 VARICK STREET • NEW YORK 13, N. Y.

EXPORT DIVISION: 13 EAST 40th STREET, NEW YORK 16, N. Y. CABLES: "ARLAB"



**GREATER CRYSTAL
STABILITY
WITHOUT OVENS**

**16-GAUGE
STEEL CASE**

**SPLATTER-PROOF
CLIPPER
CIRCUITS**

*Fleetfone—RCA 2-Way Radio for 30-50 mc band.
(Top left: Single-case construction encloses compact transmitter-receiver.)*

3 good reasons why RCA 2-Way Radio rates an expert's recommendation

Only the finest Brazilian quartz goes into the manufacture of crystals for RCA 2-Way Radio. RCA individually checks frequency and activity vs. temperature of every crystal before it leaves the plant. Variation must stay within .001 or .003% (as required) over the full temperature range—assurance of top performance in Arctic cold or tropic heat.

A 16-gauge steel case houses every RCA mobile radio unit. The added strength assures positive protection against roughest vehicle riding. In actual experiences, RCA 2-Way Radio units remained fully operative although vehicles had been completely demolished.

RCA built-in audio clipper and restoring network keep transmitter modulation well within FCC tolerances—*without sacrificing intelligibility*. Voice emissions have proved fully readable in field testing. There's no danger of "splatter," spurious noise, or interference on adjacent frequencies.

For every power and type, there's an RCA 2-Way Radio to do the job—*Fleetfone* units for the 30-50 mc band, *Cerfone* for 152-174 mc, and *UHF* equipment for the traffic-free 450-470 mc band. *Mail the coupon below for more details.*



RCA Engineering Products
Communications Equipment
Dept. F157, Building 15-1
Camden, New Jersey

Without obligation on my part, please send me your new *free* booklet on
RCA 2-Way Radio

Name _____
Address _____
City _____ Zone _____ State _____

RADIO-ELECTRONIC ENGINEERING is published monthly by Ziff-Davis Publishing Company, William B. Ziff, Chairman of the Board (1946-1953) at 64 E. Lake St., Chicago 1, Ill. Application for entry as second class matter pending. **SUBSCRIPTIONS:** Subscribers to Radio-Electronic Engineering automatically receive Radio & Television News. **RATES:** one year U. S. and possessions, and Canada \$6.00 Pan-American Union countries \$6.50; all other foreign countries \$7.00. **SUBSCRIPTION SERVICE:** All communications concerning subscriptions should be addressed to Circulation Dept., 64 E. Lake St., Chicago 1, Ill. Subscribers should allow at least four weeks for change of address.

For Continuous Adequate-Voltage **Power**

Use This **ASCO**[®]

Automatic Transfer Switch Panel

With **New** or **Existing** Emergency Power Supplies!

Conforming to RETMA Standards

Timer
Provides: 3-5 sec. delay on engine starting. 0-13 min. adj. delay on restoration to normal. 2 min. delay on stopping engine.

Close Differential Power Relay
Pickup: 88-90% of rated voltage. Drop-out: 82-85% of rated voltage. (Differentials adjustable.)

12 Volt Trickle Charger
Adjustable charging rate: .05-2 amps. Also available: 6, 24, and 32 volts.

3 Amp. Ammeter

5 Amp. Fuse

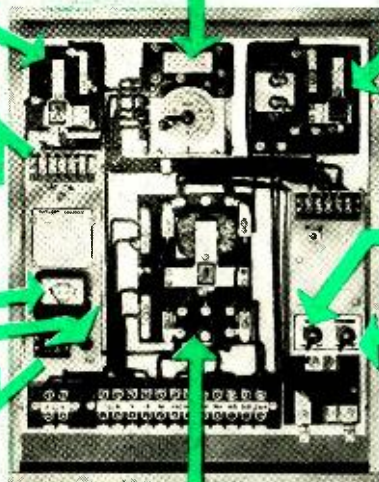

Lockout Relay
Prevents transfer until electric plant rated voltage and frequency attained.

Test Switch
Simulates normal failure.

Stand-by Switch
Disconnects engine start circuit. Permits independent operation of emergency generator set.

Transfer Switch

Normal: 115 volts/60 cycle. Emergency: 115 volts/60 cycle. 1 normally open and 1 normally closed auxiliary contacts.

CONTINUOUS POWER! An ASCO Automatic Transfer Switch transfers the load to emergency in 2 to 5 cycles when normal power fails! Once the normal source is in proper operating condition, the load is automatically restored.

ADEQUATE-VOLTAGE POWER! The Close Differential Relay shown, operating with the Transfer Switch, can provide transfer on a 5% differential in power supply voltage (less, if required). This assures adequate voltage for your installation.

This complete panel may be installed with your new emergency power supply, or may be wired into an existing installation. ASCO Automatic Transfer Switches are available up to 1000 amperes, 750 volts, AC or DC.

This Automatic Transfer Switch panel is one of many control systems designed by ASCO Engineers for Microwave installations. ASCO manufactures a complete line of Electromagnetic Controls including Solenoid Valves, Remote Control Switches, Contactors, Relays, and Complete Control Panels.



Write for your free copy today!

ASCO Engineers have developed a number of special controls for microwave power plant installations. These controls are covered briefly in a booklet titled "When Normal Power Fails . . ."



Be Sure of Continuous Power.

Automatic Switch Co.

LAKESIDE AVENUE · ORANGE, NEW JERSEY



of RADIO & TELEVISION NEWS INCLUDING

TV & RADIO & Communication ENGINEERING & Engineering

Edited by H. S. RENNE and the Radio & Television News Staff VOLUME 22 NUMBER 6

Editor and Asst. Publisher OLIVER READ, D. Sc., WIETI

Managing Editor WM. A. STOCKLIN, B. S.

Technical Editor H. S. RENNE, M. S.

Assistant Editor M. C. MAGNA

Art Editor FRANK SAYLES

Draftsmen ALBERT A. GANS JOSEPH A. GOLANEK

Advertising Manager L. L. OSTEN

Midwest Adv. Manager JOHN A. RONAN, JR.

Western Adv. Manager JOHN E. PAYNE

ZIFF-DAVIS PUBLISHING COMPANY

WILLIAM B. ZIFF (1898-1953) FOUNDER
Editorial and Executive Offices
366 Madison Ave., New York 17, N. Y.

President B. G. DAVIS

Vice-Presidents H. J. MORGANROTH M. H. FROELICH

Secretary-Treasurer G. E. CARNEY

Circulation Manager M. MICHAELSON

BRANCH OFFICES
CHICAGO (11): 64 E. Lake St.
LOS ANGELES (14): 900 Wilshire Blvd.

RADIO-ELECTRONIC ENGINEERING is published each month as a special section with a limited number of copies of RADIO & TELEVISION NEWS, and is available by subscription only.

(Average Paid Circulation Over 28,000)

COPYRIGHT 1954 (All Rights Reserved)

Eimac Klystron Report

X557

modulating anode klystron

- Beam modulation
- Easy pulsing
- Increased efficiency

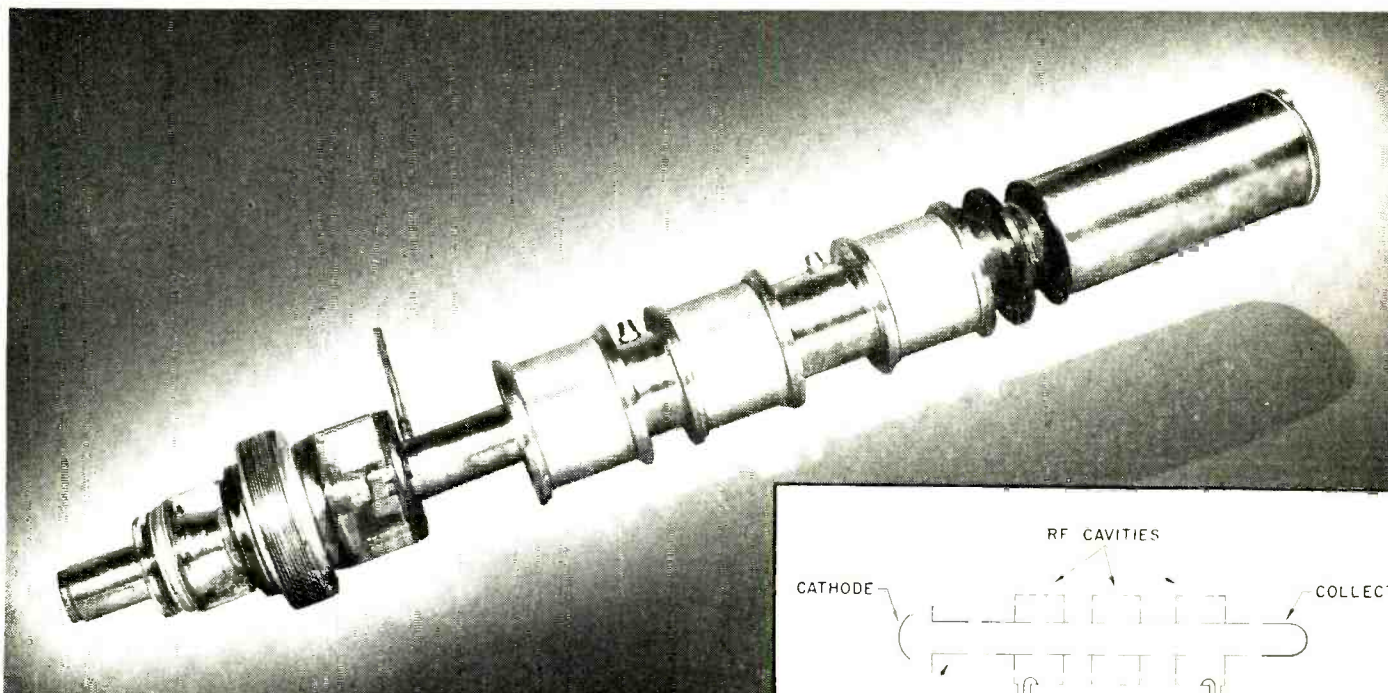

A new concept in klystron design is introduced by Eimac with the X557 modulating anode klystron. An insulated modulating anode placed between the cathode and drift tube section permits:

- Controlled variation of beam current independent of beam voltage through regulation of the modulating anode voltage
- Easy pulse modulation with low pulsing power
- Amplitude modulation with low modulating power
- 30% efficiency at carrier level with 100% amplitude modulation on top of the carrier
- Additional research and operational functions

The modulating anode klystrons are another of Eimac's klystron developments which already include high power amplifiers for UHF, including TV, and reflex klystrons for use in conditions of severe shock, vibration and sustained acceleration at frequencies to 9600mc.

- For a thorough question and answer discussion of klystrons, write our Technical Services department for a free copy of the 20-page booklet, "Klystron Facts."

EITEL-McCULLOUGH, INC.
SAN BRUNO • CALIFORNIA

Eimac

MARK OF EXCELLENCE IN
ELECTRON-POWER TUBES

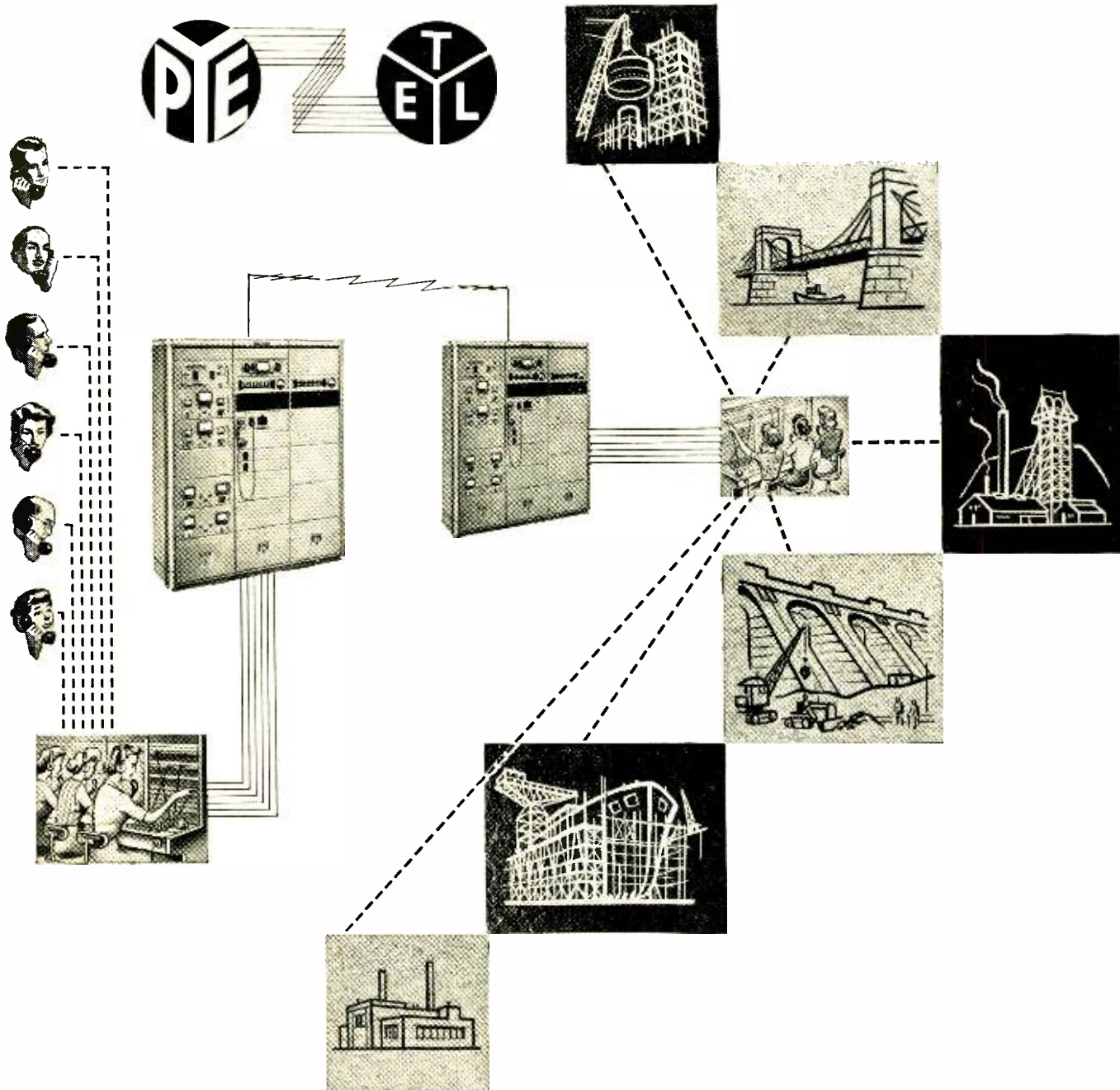

PYE-ERICSSON MULTIPLEX VHF RADIO TELEPHONE SYSTEM

The Pye-Ericsson V.H.F. multiplex radiotelephone system is already making its contribution towards the rapid expansion of telecommunications in overseas territories. Primarily developed to give telephone communication where wire and cable circuits are impracticable or, as is more often the case, uneconomical, the multiplex system provides a link that is invulnerable to both natural hazard and pilferage.

The Pye-Ericsson system retains the well established carrier technique and this, in conjunction with the inherent reliability of the equipment, assures simplicity of maintenance.

PYE LTD.
CAMBRIDGE
ENGLAND

PYE
TELECOMMUNICATIONS
CAMBRIDGE
ENGLAND



ERICSSON
TELEPHONES LIMITED
BEESTON NOTTINGHAM
ENGLAND

ERICSSON TELEPHONES LTD.
22 LINCOLN'S INN FIELDS
LONDON W.C.2. ENGLAND

MICROWAVES IN SULPHUR MINING

By A. J. LEHMAN*

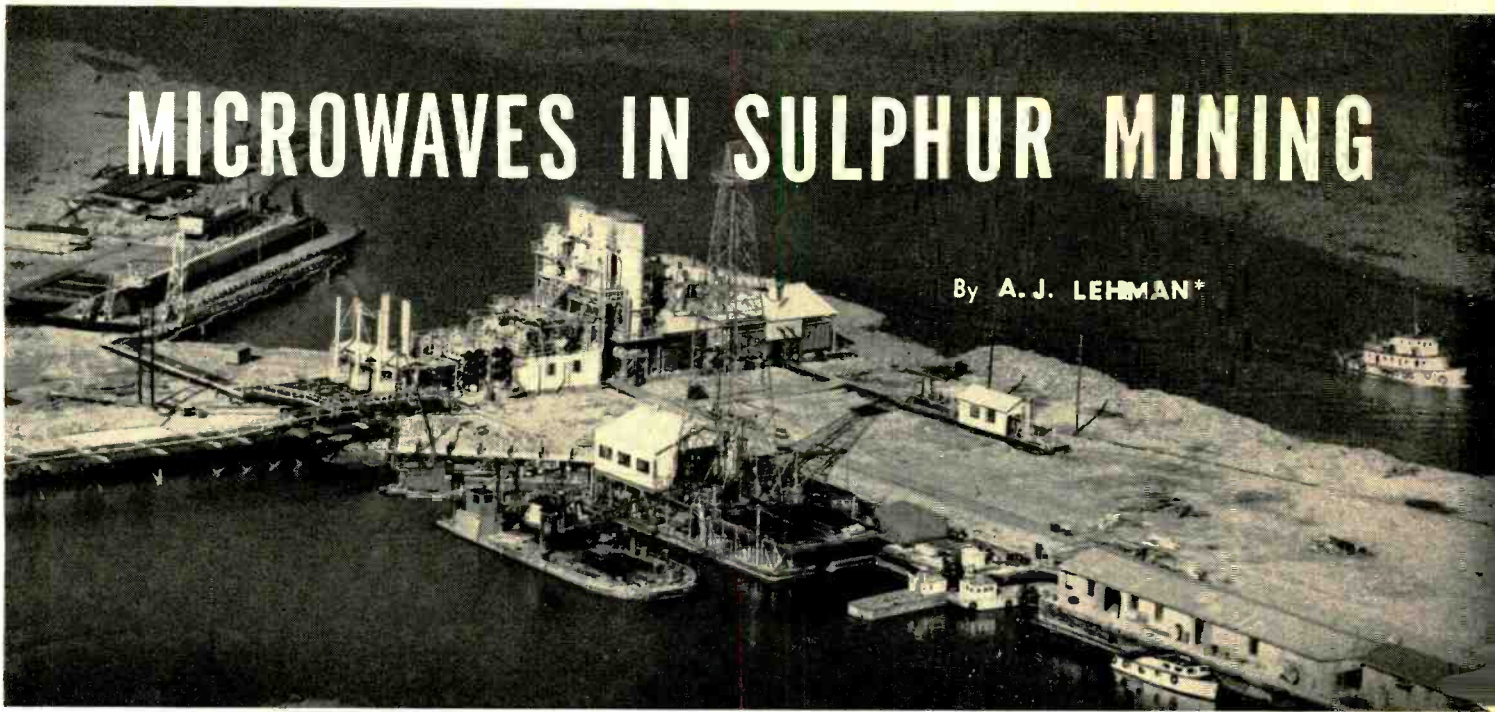

View of Bay Ste. Elaine sulphur mining operation showing mining barge, one 1000-ton liquid sulphur barge, drilling barge and LCT with clam shell on deck.

Reliable communications over difficult terrain are routine after installation of a microwave system.

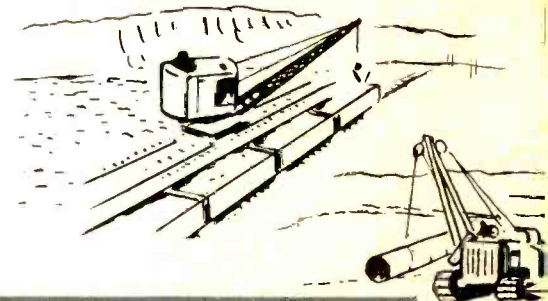

SULPHUR is one of the most important elements to mankind; in its pure and combined forms, it is used in the manufacture of almost everything with which the average individual comes into daily contact. About 70 pounds each year are used for every person in this country. A substantial percentage of this tremendous yearly consumption—about 2,000,000 tons in 1954—will be supplied by the *Freeport Sulphur Company*, operating sulphur mines in Louisiana and Texas.

The sulphur mining operation is fascinating in itself, and is described very well in a booklet available from the *Freeport Sulphur Company*. But the microwave radio system operated by this company, which is unique in many respects, is the primary concern of the present article; accordingly, only back-

ground information necessary to an understanding of the microwave system functions will be given here.

America's sulphur supply is contained in salt domes lying 800 to 2500 feet below the surface of the coastal plain stretching along the Texas, Louisiana, and Mississippi shores of the Gulf of Mexico. On a few of these domes, the sulphur-bearing limestone deposit at the top is worthy of commercial exploitation; where this is true, a great many wells are needed to exhaust the deposit, since each well is effective over only a small area. Figure 2 shows a cross section of a salt-dome sulphur mine. The section marked "unconsolidated formations," incidentally, is plain jelly-like mud.

Sulphur is procured from such mines by the Frasch process, in which superheated water is forced down an outer well casing into the limestone; the sul-

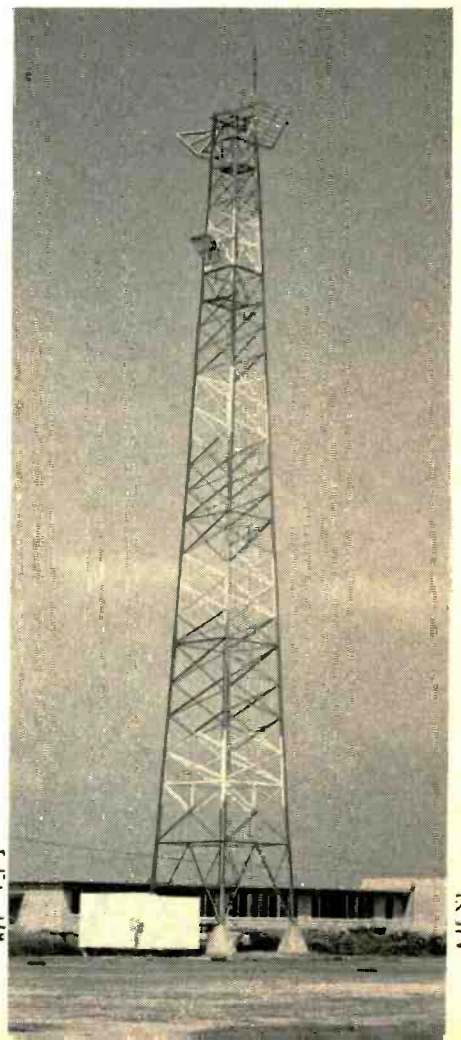

Tower at Port Sulphur. Lower reflector faces toward Grande Ecaille.

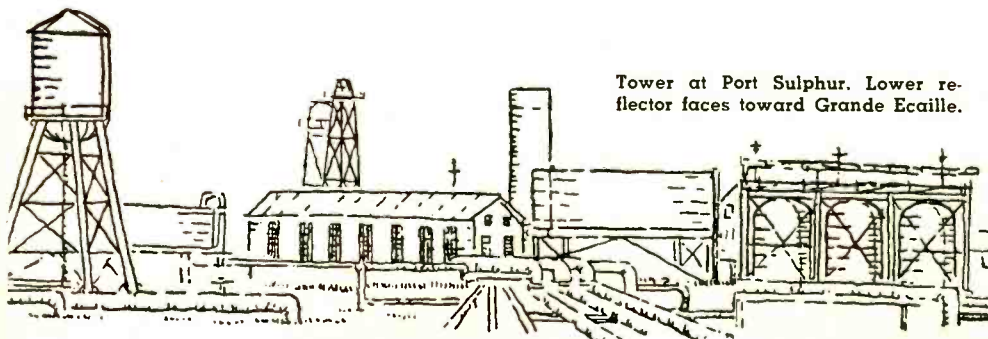

*Division Supt., Electrical Engineering, Freeport Sulphur Company, Port Sulphur, La.

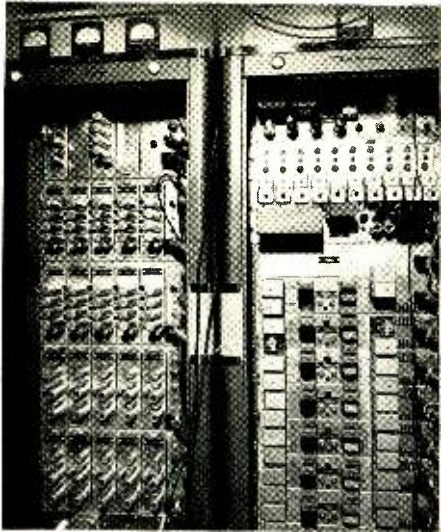

Multiplexing equipment at Port Sulphur.

phur melts out of the rock, flows to the bottom of the limestone layer, and is forced part way up a return pipe by the water pressure in the dome. In the center of the return pipe, a small compressed air line is inserted. The air lifts the liquid sulphur to the surface, where it is discharged into steam-heated pans or floating tank barges, as the case may be. Still in a liquid state, it is conveyed to a central location where it is sprayed into gigantic storage vats for solidification. When ready for shipment, the vats are broken down by power shovels

and the sulphur loaded into railway cars, inland waterway barges or ocean-going freighters.

Need for Microwave

The accompanying map of the territory involved in the Louisiana operations of the *Freeport Sulphur Company* (Fig. 1) indicates the extent of the watery terrain and reveals why the FCC saw fit to authorize construction here of the first microwave system in the Special Industrial Service. Mines are located at Bay Ste. Elaine, where even the enormous hot water generating power plant is built on a floating barge which is anchored permanently in position; at Grande Ecaille, where the entire plant and auxiliary buildings are situated on marshland so unstable that 75-foot piles sink 45 feet without being struck, and over 100,000 such piles were used; and at Garden Island Bay, on the Mississippi delta, where again all construction is held up by piling. The only approach to any of these mines is by plane or boat. Sulphur is stockpiled at Port Sulphur, about 40 miles airline down the Mississippi from New Orleans; this is the company's shipping center and the seat of field operations control. Main operating offices of the company are in the American Bank Building, New Orleans.

Obviously, in an operation of this nature and scope, there must be instant, reliable communication facilities avail-

able at all times between Port Sulphur and New Orleans, as well as from both headquarters to each of the mine fields. Telephone lines could be (and have been) built between New Orleans and Port Sulphur. But the cost of building and maintaining wire lines on poles dropped into the gooey unstable terrain around Bay Ste. Elaine or Garden Island Bay, for instance, would be fantastically high if the job were possible at all. Dependability would be extremely questionable, too, because the weather in that territory is notoriously capricious. In a situation of this nature, then, a microwave system was not simply the best but was the only solution to the communication problem. Working closely with *Motorola* engineers, a 6700-mc. system was designed and installed. This system has been operating successfully now for well over a year, and was just recently converted from a local and common battery system to a dial system.

Plan of the System

Port Sulphur can be considered the central terminal, with legs to New Orleans, Bay Ste. Elaine via Grande Ecaille, and Garden Island Bay. At Phoenix, Leeville, and Venice, straight repeaters are located.

R.F. units are standard *Motorola* 6700-mc. "Micropackage" and remote transmitter-receivers with klystron output stages. All installations in the sys-

Fig. 1. Microwave installations in Louisiana area are indicated by numbers (1) through (8); (1) is New Orleans and (5) is Garden Island Bay.

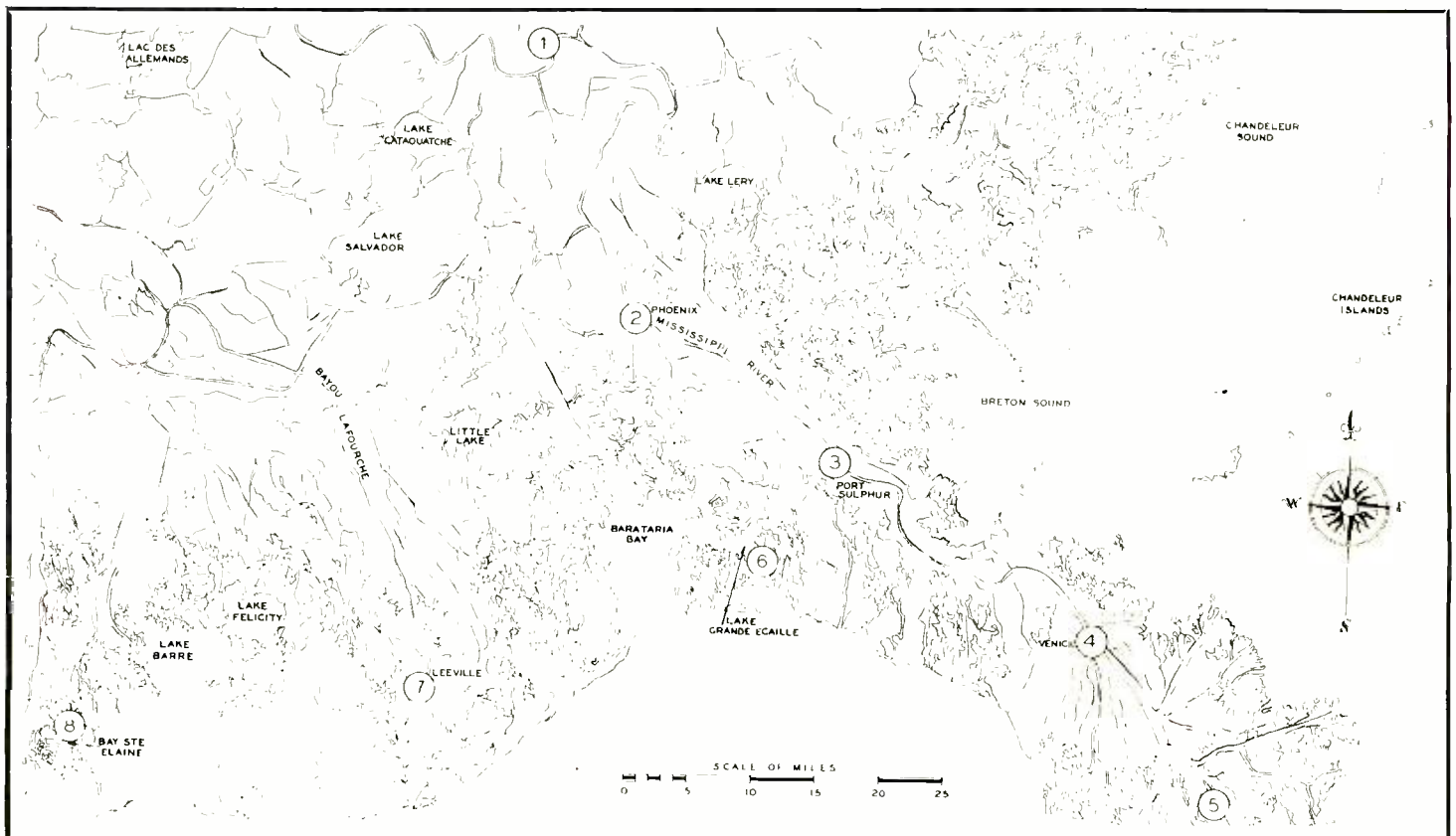

tem employ tower-mounted reflectors with the exception of the New Orleans terminal, where the r.f. unit and parabolic antenna are mounted on the roof of the American Bank Building; the multiplex apparatus and voice terminals are on the 24th floor, connected by audio lines to the 15th-floor switchboard. The r.f. equipment is capable of carrying 12 voice channels, although all channels are not in use at the present time.

From Port Sulphur to Phoenix, five telephone channels are utilized. One is dropped at the Phoenix repeater; the remaining four, all private lines with 20-cycle ringing, go through to New Orleans.

Six channels are in use between Port Sulphur and Venice. One is a telephone channel that is dropped at Venice, and four are telephone channels that go straight through to Garden Island Bay. The remaining channel is for control of the v.h.f. system, operating simplex on 152.87 mc., which is used for communication with the company's 46 mobile units. These are primarily marine vessels—sulphur barges, tugs, and the like.

Eleven full voice channels are carried on the Port Sulphur-Grande Ecaille leg. Five are used as telephone channels to Grande Ecaille, and the rest are repeated through to Leeville. Two are
(Continued on page 47)

Temporary pole and reflector at Garden Island Bay installation with crossarm to minimize twist.

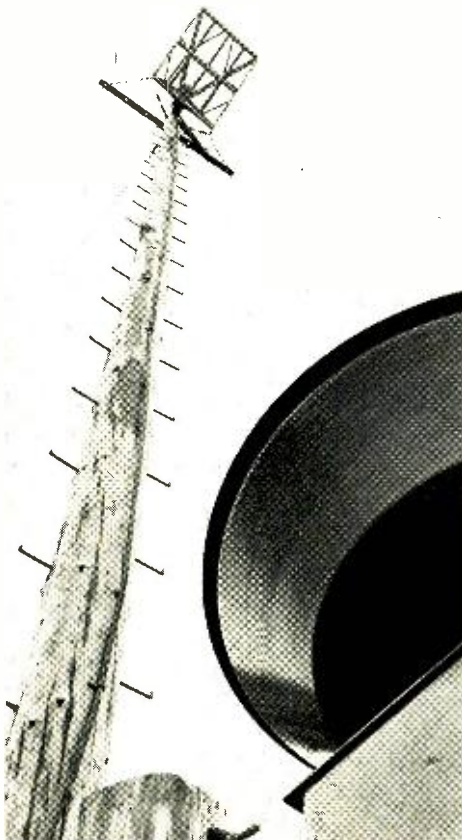

Reflectors on tank at Grande Ecaille.

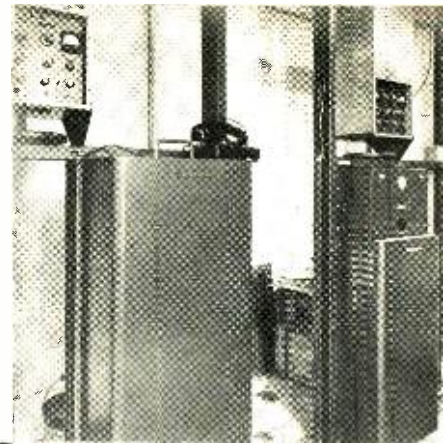

"Micropackage" repeater at Venice.

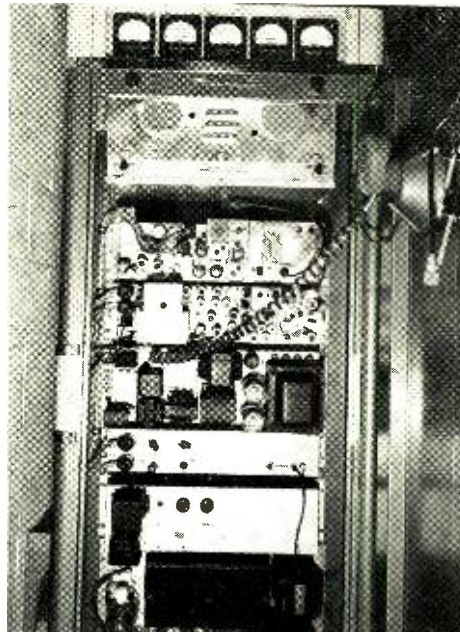

The v.h.f. transmitter-receiver installation at Port Sulphur.



Remote-type r.f. unit at base of water tank at Grande Ecaille.

Fig. 2. Cross section of a salt-dome sulphur mine showing the various layers above the salt dome. Superheated water melts the sulphur in the sulphur bearing limestone, and the mixture is forced to the surface by compressed air.

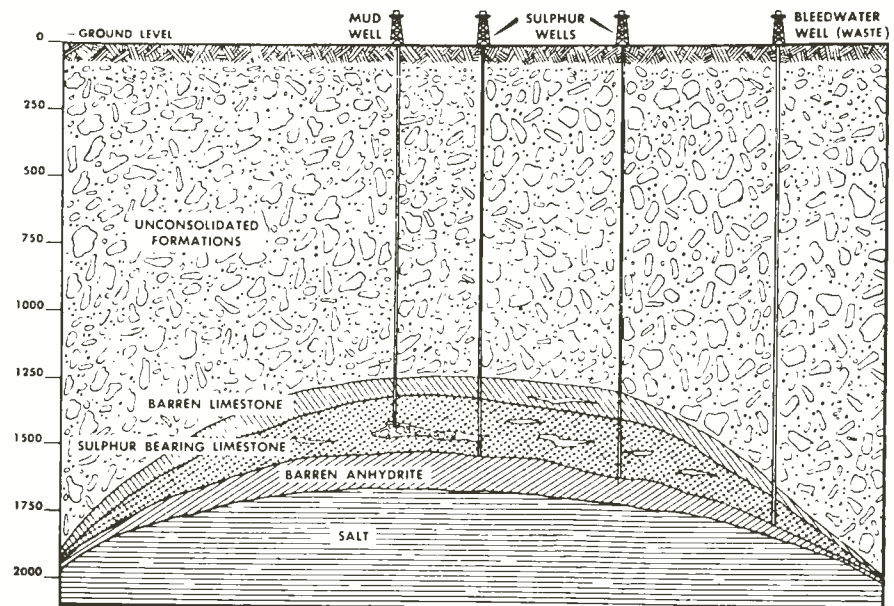

VERSATILE

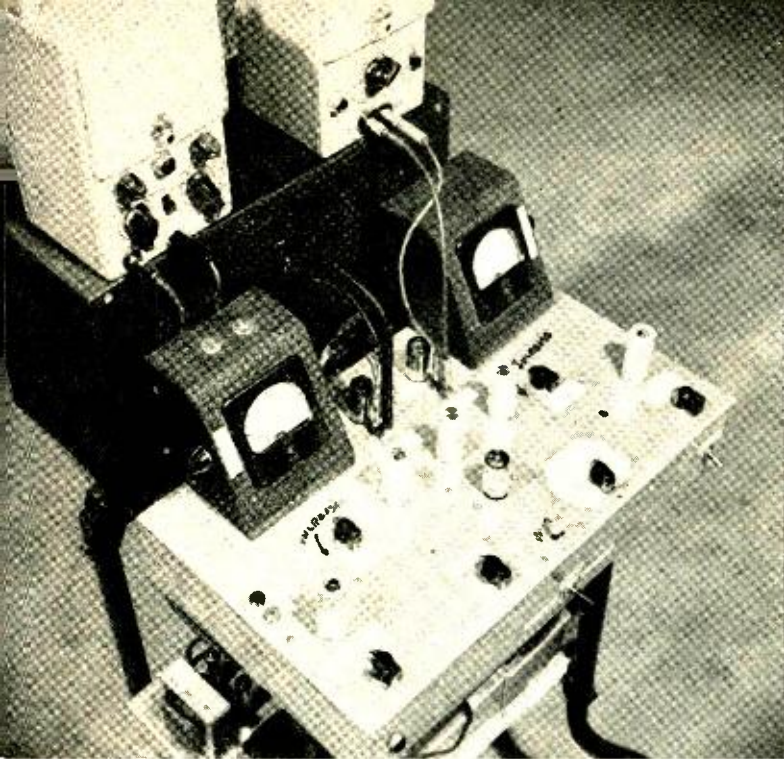
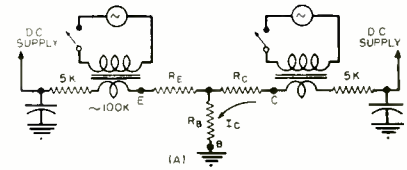

Fig. 1. Equivalent circuits for measuring (A) R_B and R_E , (B) α , and (C) R_X .



Transistor tester set up for measuring characteristics of point-contact and junction transistors.

By **JAMES GIBBONS***

Stanford University

Basic characteristics of point-contact or junction transistors can all be measured with this tester.

INTELLIGENT use of a transistor as an electronic circuit component involves a knowledge of its equivalent circuit parameters. The device to be described in this article has been developed to make reasonably accurate measurements of the low frequency parameters of both junction and point-contact types of transistors.

Fundamentally, the measurement problem for transistors is similar to that for vacuum tubes, namely, that the

desired operating point be established and the equivalent circuit a.c. parameters be measured at that point. This test equipment utilizes transformers to inject the a.c. signal into the transistor in series with the d.c. biasing currents. Application of the measuring signals in this manner circumvents the problems associated with the construction of high impedance d.c. supplies (which would be required if the d.c. and a.c. signals were applied in parallel) and

results in considerable simplification of the test apparatus.

Essential features of the tester can be adequately described with the aid of the block diagram in Fig. 2. The transistor obtains metered emitter and collector bias currents from the current supplies, which are independently variable. The "n-p" switch provides for reversal of the supplies for the two types of biasing arrangements required. Bias voltages are read by connecting a voltmeter to the collector and emitter terminals. It is not advisable, however, to use these readings as indications that the correct bias conditions have been obtained; for any given set of bias voltages, two sets of bias currents correspond, one of which can possibly damage the transistor permanently.

When the correct bias conditions have been obtained, the tester is calibrated for the measurement of the transistor a.c. parameters. Calibration is effected by connecting the emitter a.c. signal supply to its input transformer and adjusting the signal input until .05 volts r.m.s. is read from the "Cal I_B " point to ground. This reading indicates a current through the standard 5K resistor of .01 ma., or 10 μ a. One end of the calibrating resistor is grounded to the signal by the capacitor C_1 . The collector signal is similarly calibrated. The transformers are arranged so that the signal current is stepped down from the signal supply to the transistor circuit, yielding several important advantages over a step-up connection for the current:

1. Transistor impedances are stepped down when reflected to the input side of the transformers, and their effect on the a.c. signal current regulation is negligible.
2. For a given measuring current (.01 ma.), the actual current in the signal circuit is larger and much easier to regulate.

When the supplies have been calibrated, the function switch can be turned to select any of various parameters to be measured. Conditions to

Fig. 2. Block diagram of the complete transistor tester.

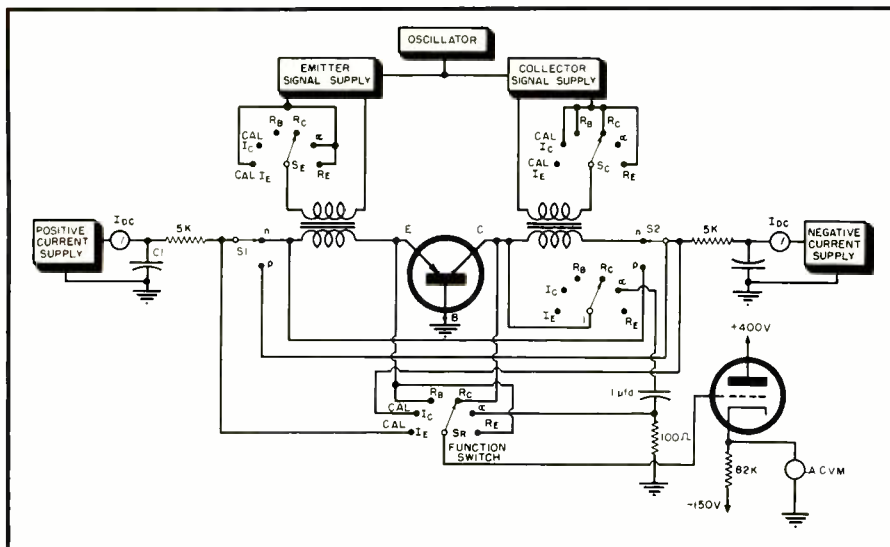

*Formerly with Tung-Sol Electric Inc.

TRANSISTOR TESTER

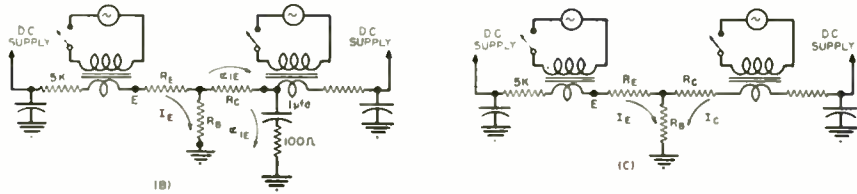

be met for the various measurements depend primarily on the parameters to be measured, and will be discussed below in detail.

To measure R_n , the emitter signal transformer primary is opened, and the collector signal current is allowed to flow. The equivalent T circuit for the transistor is then that shown in Fig. 1A. Since the secondary of the emitter input transformer will have an impedance in the hundreds of thousands of ohms at the operating frequency, the collector current may be considered as flowing through the base resistance to ground. The error here is small enough so that it cannot be discerned on the voltmeter. Consequently, the voltage developed from "E" to ground is $R_n \times I_c$, or $R_n \times 10^{-5}$ volts.

To measure R_c , the same connections as above are used, except that the collector terminal voltage is read. This reading is actually a measure of $R_c + R_n$, and the reading of R_n just obtained may be subtracted if desired. However, with R_c in the tens of thousands of ohms, and with R_n in the 10-1000 ohm range, the error involved in calling the voltmeter reading $R_c \times 10^{-5}$ is quite small for point-contact types of transistors and negligible for junction types.

The measuring circuit for α depends on the definition of this parameter as the short circuit collector current which flows when an emitter signal is applied. This definition is translated in the tester to an opened collector primary, a closed emitter primary, and a large C and small R in series from the collector to ground. When these changes have been made, the transistor T circuit is that shown in Fig. 1B. Current flowing in the collector load is then $\alpha \times I_e$, or $\alpha \times 10^{-5}$ amperes. The voltage developed across the 100-ohm resistor is then $\alpha \times 10^{-3}$ volts, so the voltmeter reads α directly.

To measure R_n , the circuit of Fig. 1C is used. Here, both emitter and collector currents flow, each being .01 ma. in magnitude. However, the transformers are so arranged that these currents are

180° out-of-phase, and their effects in the base resistance cancel. Hence, the voltage from "E" to ground is $R_n \times 10^{-5}$ volts. It may occur to the reader that since two currents are being subtracted in R_n which are of nearly equal magnitude (ideally equal), large errors could occur. However, any error voltage gives a reading that is in series with the actual R_n voltage, which is considerably larger than the voltage developed in R_n due to the difference of the two currents. Measurements of T pads with known resistances prove such apprehension to be unfounded when the tester is properly calibrated.

The circuitry used to generate the various signals is shown in Figs. 3A, 3B, 4 and 5. Figures 3A and 3B, the d.c. supplies, are merely 6CB6 pentodes with floating bias supplies. Bias voltages are obtained from potentiometers connected across voltage regulator tubes, the position of the potentiometer arm determining the bias current supplied. Biased diodes around each supply prevent destructive currents from flowing. Extreme precautions to avoid hum and other undesirable signals are unnecessary since a large amount of decoupling can be used before the bias currents are injected into the transistor.

Figures 4 and 5 depict the tubes and associated circuitry which are used to generate the a.c. signals. The two-thousand-cycle master oscillator is of the Wien bridge type, and two 6BA6 pentodes are fed from the output of this oscillator for the a.c. signal sources. Resistors in the cathode leads of the pentodes provide sufficient degeneration so that the reflected load from the transistor circuit has no effect in determining the circuit current—a desirable feature, since a single calibration of the instrument then suffices for many measurements.

The measuring circuit consists of a cathode follower with an 82K load resistor and a.c. voltmeter in parallel. The cathode follower serves to isolate the measuring instruments from the rest

(Continued on page 46)

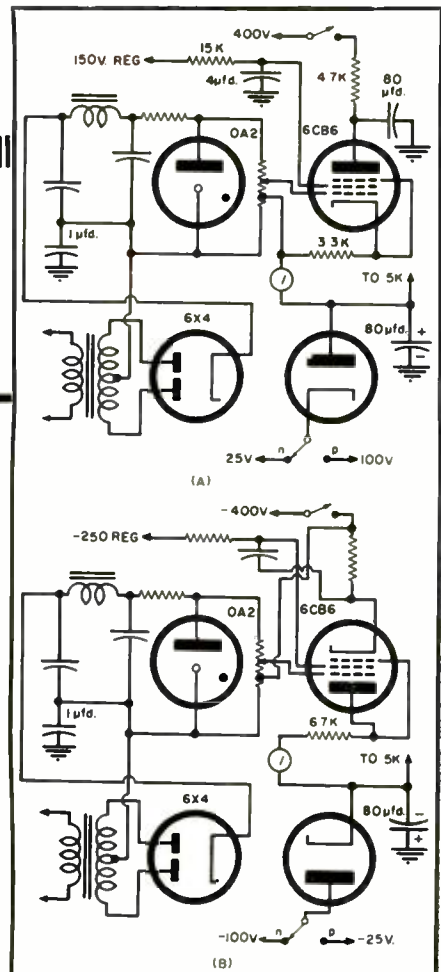

Fig. 3. Circuits of d.c. supplies for (A) positive and (B) negative voltages.

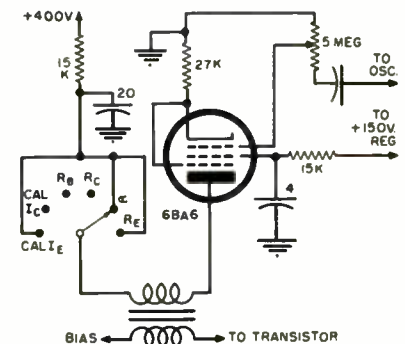
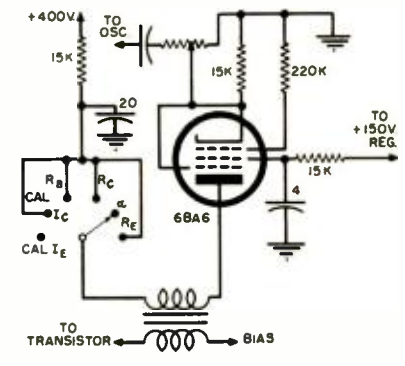

Fig. 4. Emitter signal supply circuit.

Fig. 5. Collector signal supply circuit.



EQUIPMENT

By **LEONARD S. SCHWARTZ**

College of Engineering
New York University

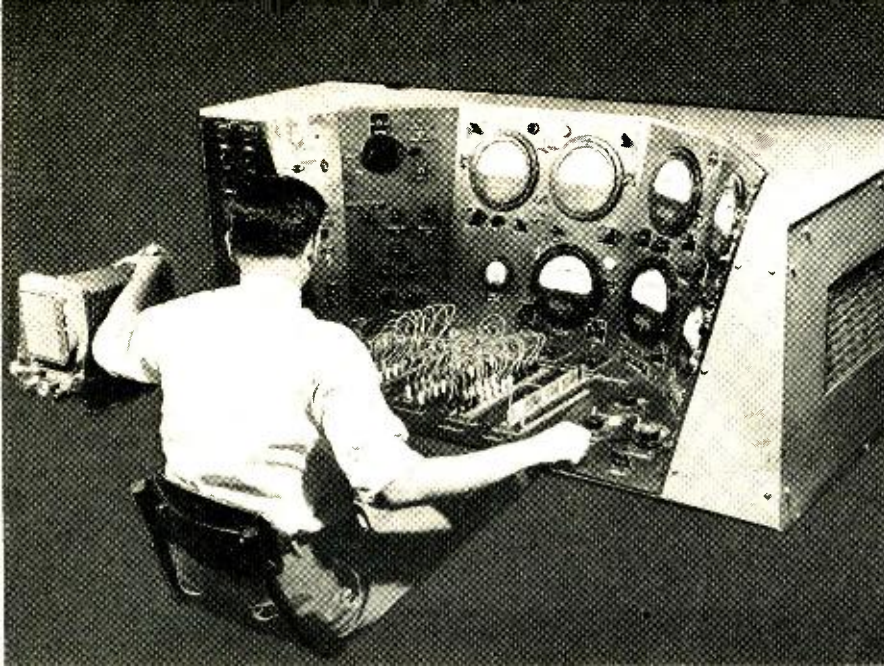

Console-type electronic tube characteristic curve tracer developed by Sylvania's Product Development Laboratories. Camera for photographing curves is at left.

Tube redesign, proper application, maintenance and environment considerations add to system reliability.

INSPIRED by an increasing failure rate resulting from the ever-growing complexity of military electronic equipment, interest in the reliability of electronic equipment has increased tremendously in recent years. This interest has for its object the improvement of equipment reliability.

In any program to attain this objective, it is helpful to have a definition and a quantitative measure of reliability. As applied to electronic equipment, reliability has come to mean the probability that the equipment will perform as specified for a given length of time under a given set of operational conditions. A useful measure of reliability has been found to be mean time-to-failure.

Equipment Complexity

To determine the dependence of equipment reliability on equipment complexity, the nature of failures in equipment must be understood, and a measure of equipment complexity must be established. Failures seem to fall into three classes, those that arise from: (1) initial defects, (2) chance stresses and (3) wear-out. Consider each class of failure in turn.

1. Initial failures result from an event in the preoperational life of the component, such as an error in manufacture or damage in transit. Since initially defective components rarely are put into operational use, they will not be considered further here.
2. Chance or random failures include such failures as tube puncture or capacitor breakdown. They are generally the result of unpredictable stresses produced by environmental factors such as temperature, shock, and/or vibration.
3. Wear-out failures result from the depletion of a material or physical property necessary for proper operation. Most wear-out failures can be anticipated, since the times of failure for a group of similar components are known to be normally distributed about a readily determined mean. Techniques are being developed for the early detection of in-

ipient wear-out failures in equipment employing large numbers of vacuum tubes as a means of preventing costly breakdowns during operation. Advance warning of failures in vacuum tubes can be obtained through monitoring their transconductance, grid current, and other characteristics.

In airborne radar equipment, failures are primarily of the chance or random type, arising from randomly occurring environmental stresses which drastically reduce the service life of the equipment. From a study of failure data, it is possible to obtain failure rate constants by means of which one can predict the operational reliability to be expected of newer, more complex radars now being prepared for service use, assuming that these newer sets would be constructed and employed in similar fashion to the earlier models. It has been found that the complexities of certain equipment have reached the point where, on missions of average duration, its reliability decreases to values that are not militarily acceptable. Data quoted by Boodman¹ show that the average service life of components in airborne use is 1400 hours for vacuum tubes and 5000 hours for other electrical parts, a small fraction of their bench life. The rather brief useful life of these components in airborne radar equipment is evidence that the failures occur as a result of randomly occurring severe stresses rather than wear-out.

The reliability of a piece of equipment is a function of its complexity and the reliability of its components. The complexity of equipment is difficult to measure except in comparative terms. In electronic equipment, complexity may be expressed approximately in terms of the number of electron tubes which must operate simultaneously if the equipment is to perform as desired. For a strictly accurate analysis, other components besides tubes would have to be considered, but it is instructive to

Fig. 1. Over-all equipment reliability as a function of the number of components n and the component reliability.

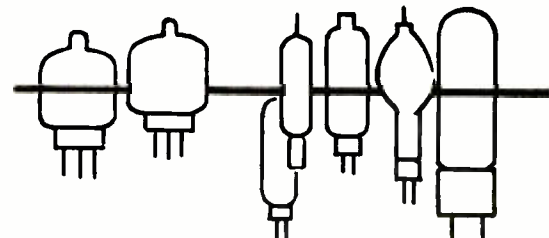
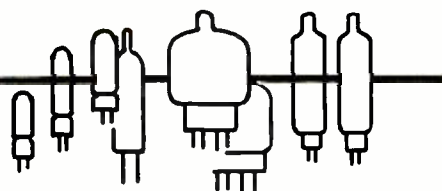
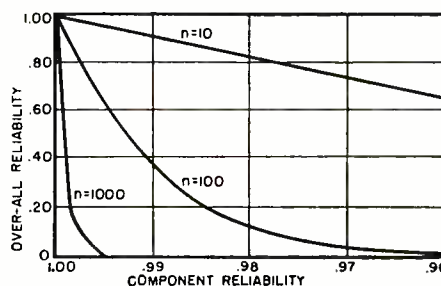

COMPLEXITY AND TUBE RELIABILITY

look at the simplified picture. Since the reliability of each component of an assembly can reasonably be considered to be independent from any other, the total reliability of the assembly can be stated by the well-known expression for the probability of simultaneous occurrences, namely,

$$R_t = R_1 R_2 \cdots R_n \dots \dots \dots (1)$$

where R_t is the reliability of the assembly, and $R_1 R_2 \cdots R_n$ are the component reliabilities. The curves of Fig. 1 are plotted for $R_1 = R_2 = \cdots = R_n$ and demonstrate to what extent the reliability of the components must be greater than that of the assembly. It is seen that the less reliable components strongly affect the reliability of the assembly. For example, if the assembly is made up of only ten components, the failure of any one component means failure of the assembly. Thus, a reliability of 0.90 in each component means a reliability of only 0.35 for the assembly; a component reliability of 0.99 is essential for a total reliability of 0.90. Empirically, it has been determined¹ that an airborne radar unit consisting of 100 vacuum tubes and 1000 other electrical components has less than a 77% chance of surviving for two hours; a unit with 250 vacuum tubes and 2500 other parts has approximately a 50% chance of surviving for the same period.

Tube Failure Factors

Failure data indicate that tubes are the biggest single source of failure in electronic equipment, accounting for something over 50% of all failures. The seriousness of this situation is underlined by the fact that individual tubes were selected and tested prior to installation in equipment.

Component unreliability does not appear to be localized in any particular area of the Military Services or in any particular class of equipment. Moreover, the causes of failure seem to be fairly well dispersed over design, manufacture, and usage. More detailed knowledge of all the conditions to which components and equipment will be subjected is needed to permit reliable de-

signing. The true capabilities of the available components should be known so that they will not be misapplied; and where necessary, more suitable components should be provided. Field trials should be conducted to correct mistakes before quantity production begins, and better specifications should be written and enforced.

Moreover, it is necessary to know the relative importance of various factors involved in tube failure, which are: (1) tube design, (2) manufacturing methods, (3) applications, (4) maintenance, and (5) environment. And most difficult of all, the factors that cause failure must be isolated, a problem in the design of experiments. It is a problem in which there may be interactions between causes and in which two or more causes may occur simultaneously or in sequence. The causes may be statistically independent, i.e., having no correlation with each other; this is the simplest situation to resolve, since it involves the least complicated testing program. If the causes are interdependent, the dependence may be complete; in this case, the causes can be combined and treated as one composite cause. On the other hand, the more likely situation is to have varying degrees of dependence.

Improving Reliability

The question of how to improve component reliability now arises. Consideration of the over-all reliability problem has shown the need for such improvement. Once agreed upon the yardstick of mean time-to-failure with which to measure reliability, one can determine which components or which pieces of equipment are relatively more defective. Having ascertained the elements that require attention, one can then endeavor to isolate the specific causes of inadequate reliability. Since, as has already been indicated, the vacuum tube is the single most important component causing equipment failure, discussion henceforth will be concentrated on this component.

Tube Design

It became evident to the commercial

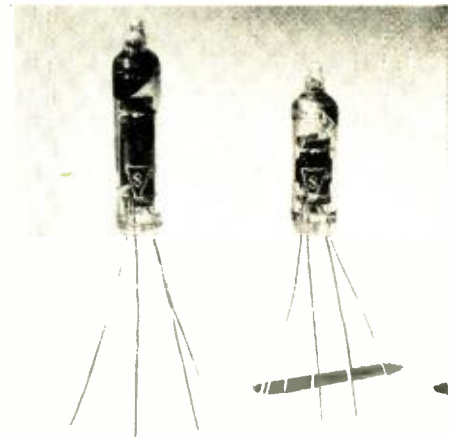

Two Sylvania "premium" subminiature tubes.

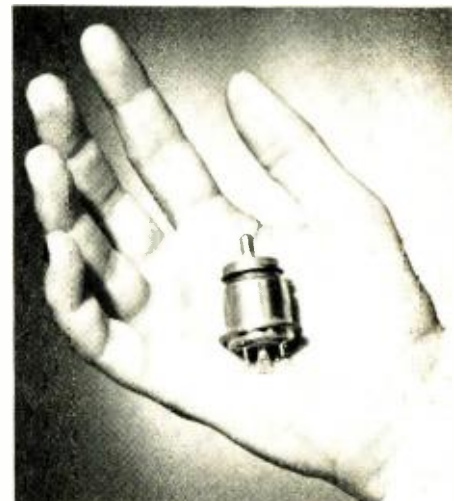

A Western Electric Type 416A triode tube.

RCA special aging rack for miniature tubes.

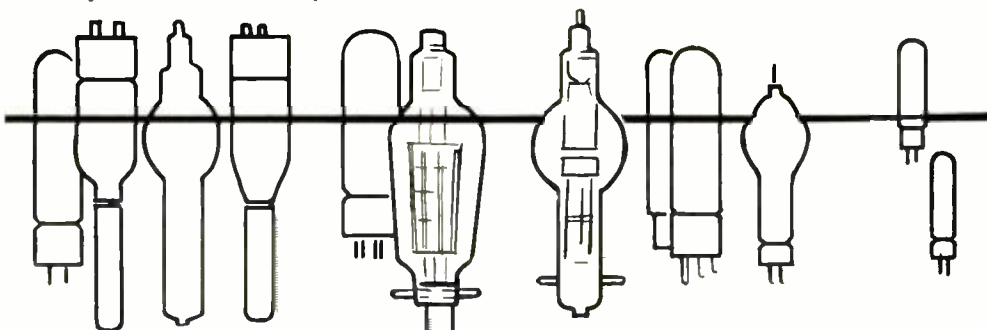

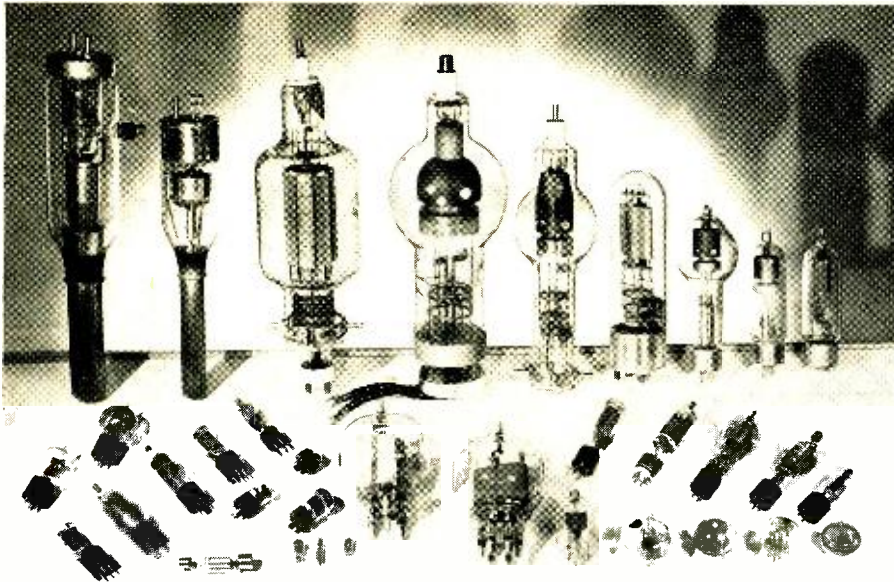

A representative group of commercial Western Electric electron tubes.

airlines several years ago that even with all possible preventive maintenance the percentage of unpredictable failures occurring in flight could not be tolerated. This was increasingly true as more electronic equipment was added, such as glide-scope receivers, omnirange directional indicators, and automatic pilots. As a consequence, their nonprofit engineering group, *Aeronautical Radio, Incorporated (ARINC)* approached the tube manufacturers with a proposal for making more reliable tubes by improvement of the design and manufacturing techniques, with cost of secondary importance. Redesign of basic miniature types having wide application in airline equipment was undertaken, and *ARINC* simultaneously began working with the equipment designers to redesign circuits so that they would require only tubes from this list, specifying conservative operating conditions wherever feasible. Later, the Navy became interested to the extent of sponsoring the redesign of three of the tube types, and it was decided to combine the objectives to make the tubes suitable for both aircraft and military requirements.

The first obvious point of attack was the filament, or heater, since airline use subjects tubes to a wide range of voltages combined with many short on-off periods of operation in the transmit-receive portions of the equipment. As a part of this investigation, tubes which failed in service were returned by *ARINC* to allow analysis of the causes of failure, and simultaneously factory tests were set up to duplicate operating conditions; on some types, it was found necessary to increase the heater current in order to use a larger-diameter tungsten wire. The next effort was devoted to elimination of interelectrode shorts,

particularly under shock and vibration; this was done in most cases by keeping structures short in relation to their diameters, using double micas for support, adding clips to hold elements in place, and in general stiffening the weak points which showed up under high impact shock test. Another important result of failure analysis was the establishment of a 50-hour burn-in period to eliminate "infant" failures remaining in the product even after the most careful manufacturing procedures. Needless to say, production methods were drastically revised to incorporate additional parts inspection, special handling, and more experienced operators; but even with all this, there still remained a small, unavoidable percentage of tubes coming off the exhaust machine which were destined to fail or have unstable characteristics during the first few hours of life.

In addition to the design and manufacturing improvements, a program was instituted to control electrical characteristics more closely by a statistical method involving the use of control limits on the important items. If measured products fall outside the limits, the lot is returned for reprocessing and reinspection. The daily control of testing has resulted in a much more uniform product than would be the case if the characteristics were allowed to wander uncontrolled between the over-all maximum and minimum limits. Some appreciation of the problem may be gained by referring to the spacings of a typical twin-triode, the 5670, where a quarter-of-a-thousandth variation may result in a 10% change in one of the characteristics.

There are several other aspects of reliability now being considered by the military and various standards agen-

cies, the most controversial being the problem of writing down a specification for a reliable tube. The original proposal by *ARINC* was to make the best tube possible, and not tie it down at any particular stage of development by a detailed specification, as that might prevent or delay incorporation of beneficial changes in tests, characteristics, or ratings. The demand for a definite specification for military purposes, however, finally outweighed these considerations, and Joint Army-Navy (normally referred to as *JAN*) specifications were proposed and issued.

It should be understood that a specification cannot automatically yield a reliable tube. Qualities of reliability must be inherent in the design of the tube and must be built into it. The specifications should insure that nothing characteristic to the tube changes and that the product is inherently the same from one week's production to the next. Before any acceptance and control specifications can be written, there must first be adequate data available on which to establish the process average of the various characteristics. In writing any such specification, two things should be kept in mind: (1) tolerances on important characteristics should be kept to a minimum commensurate with field requirements, and (2) tolerances specified should conform to the process average on the product when it is run in the best controlled fashion. When either of these two concepts is violated, a product is specified that either is unacceptable in the field or is not producible in the manufacturer's plant.

Tube Production

What general steps are being taken to improve tube reliability? It is now standard policy within the Department of the Army, especially on Signal Corps and Ordnance equipment, to request manufacturers developing equipment to fill out tube characteristic charts indicating the operating conditions and environment of each socket in the circuit. These charts are analyzed by qualified engineers in the government laboratories to see that correct tube types are used correctly.

Moreover, the Services have coordinated a program to improve the reliability of existing tube types. This program may be roughly divided into two parts, a tube production and a tube improvement program. The production program has called for the inclusion of a part of the *ARINC* line of tubes in the *JAN* Preferred List. The Services have helped to expand the capacity of industry to produce the *ARINC* tubes, as well as to support efforts to improve the reliability of other tube types. For example, the Air Force-supported

(Continued on page 45)

By **F. A. RANSOM***
National Bureau of Standards

TIME-PROPORTIONAL ELECTRONIC THERMOSTAT

A VERSATILE electronic thermostat is now in use at the National Bureau of Standards as a general-purpose temperature controller for a variety of applications. Designed for flexibility and high sensitivity, it provides precision temperature control over a wide range of temperature and power requirements. Power supplied to the heating element is switched on and off in a regular cycle, but the fraction of the cycle during which the power remains on is proportional to the deviation from the desired temperature.

Featured in this device are such advantages as (1) no appreciable dead zone; (2) sensitivity which may be raised very high without objectionable loss of stability, thereby reducing the deviation from the control point to a minimum with any load changes; (3) capability of handling power requirements ranging from milliwatts to kilowatts for control; (4) use of a sensing element which may be a resistance thermometer or a thermistor connected in a bridge circuit or a thermocouple connected to a chopper circuit; and (5) use of standard commercial components.

The temperature-sensing element is connected in one arm of an a.c. bridge, the adjacent arm of which is a variable resistor adjustable to the desired temperature control point. A 164-cps oscillator energizes the bridge and also supplies synchronizing voltage to a twin-diode synchronous detector. When the actual temperature at the sensing element deviates from the control temperature, the resulting bridge error signal is amplified and applied to the center leg of the synchronous detector. The resulting current in the center leg is determined by the amplitude and phase of the error voltage, being zero when the error voltage is zero.

Also applied to the detector, in series with the error voltage, is a voltage from a sawtooth oscillator. The output of the detector then consists of a sawtooth voltage that operates about a reference level which varies with the error voltage. This detector output is applied to a Schmitt trigger circuit, which in turn actuates a relay that switches the power applied to the control heater.

With this arrangement, when the temperature deviation and thus the error voltage are zero, the sawtooth voltage applied to the detector can be adjusted so that the control relay applies power to the heater 50% of the



Front view of two-channel model developed at NBS.

Electronic control of duty cycle of heating element permits temperature to be accurately controlled.

time. Any temperature deviation from the control point then alters the proportion of the "duty cycle" during which power is applied to the heater; this proportion varies above or below 50% depending on the magnitude and direction of the temperature deviation. Large temperature deviations, beyond the proportional control range for which the instrument is set, result in the heater power being either on or off continuously—depending on the direction of the deviation—until the temperature is again brought within the proportional range. The duty cycle, determined by the frequency of the

sawtooth oscillator, is designed to be adjustable over a range of about 5 to 15 seconds to meet the needs of any particular controlled process.

Since the controller is of the time-proportioning type, its time of response to a temperature change is slightly longer than that of other types of controllers. Also, if the total power is switched in the control of processes having small thermal capacities and short thermal time lags, the temperature may cycle about the control point. In such cases, the magnitude of the cycling can easily be minimized, supply-

(Continued on page 33)

Schematic diagram of the time-proportional control circuit.

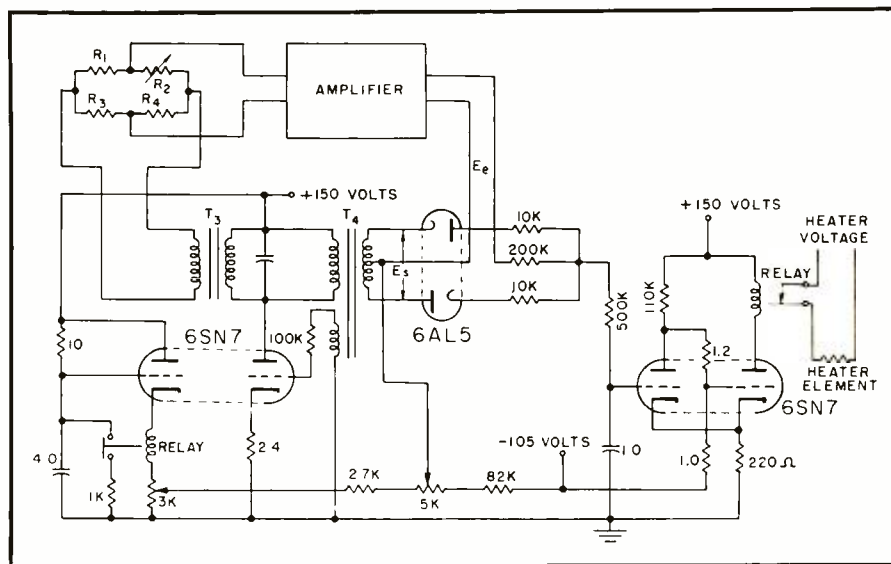

*Now associated with ACF Electronics.

POWER SWEEP GENERATOR FOR U.H.F.

By **DUANE M. WEISE***

Chief Engineer, KOM-TV
University of Missouri

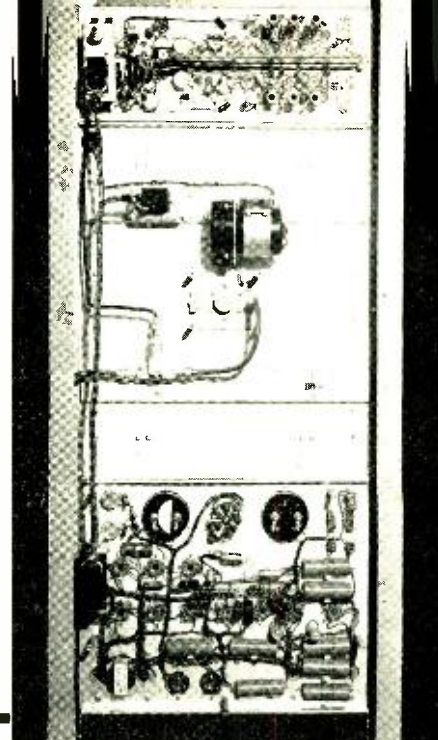
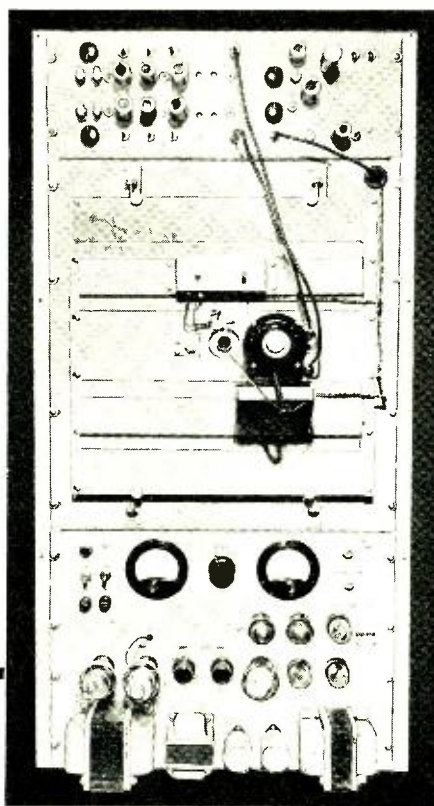

Fig. 1. Front (left) and rear (right) views of complete unit. Three chassis are used—a sweep oscillator, a marker generator, and a dual power supply.

RAPID progress in the establishment of new u.h.f. TV stations across the country substantiates the development strides that were made in the laboratory during the period of the TV freeze. A good portion of this laboratory development work was devoted to modifying or designing new test equipment which covered the 470 to 890 mc. u.h.f. TV frequency band.

An invaluable piece of test equipment to be developed for this band was the sweep generator. To date, several sweep generators have been placed on the market; however, for the most part, these units have been designed for testing television receivers and, consequently, are of low power.

The development of a power sweep generator for the testing of passive networks such as filters, duplexers, and antennas, and for testing power amplifier stages of u.h.f. TV transmitters, was undertaken. Use of a power sweep generator on passive circuits has the definite advantage that detection may be accomplished in the more linear

*Formerly project engineer at General Electric Company.

region of the detector characteristic. As designed, the u.h.f. sweep generator to be discussed here has a nominal power output of 10 watts. In addition, to meet other exacting requirements for the testing and alignment of transmitting equipment and its accessories, a sweep flatness of .05 db/mc. has been achieved.

Figure 1 illustrates the sweep generator unit, which consists of three chassis: a sweep oscillator, a marker generator, and a dual power supply.

Cavity Oscillator

Considerable experimentation had been made toward the development of a u.h.f. power sweep generator using open lines or transmission lines as tuning elements and also using a cavity oscillator. These experiments indicated that satisfactory operation over the u.h.f. band could be most readily achieved with a cavity oscillator type of generator.

The sweep oscillator chassis consists of a GL-2C39A tube seated in a tunable rectangular cavity and operated as a grounded-grid oscillator. Figure 3 illustrates the circuit arrangement em-

ploying this cavity. The GL-2C39A tube was selected for operation as a grounded-grid oscillator because of its reasonable cost, adaptability to cavity mounting, and power rating.

In the initial development of the oscillator unit, external plate-to-cathode feedback was employed which was adjustable in phase and amplitude. The results of this investigation were not satisfactory due to the additional internal feedback that took place through the interelectrode capacity of the tube. Satisfactory operation over the u.h.f. band using both internal and external feedback was not realizable, so one or the other had to be eliminated. As efforts to reduce the interelectrode feedback proved difficult, the external feedback was discarded. The internal feedback through the plate-to-cathode tube capacity was subsequently increased in order to be effective over the u.h.f. band. This was accomplished by extending the common r.f. return path for the plate and cathode currents which flowed to the grid circuit.

The sacrifice of amplitude and phase control of the feedback voltage, through

Fig. 2. Steps showing how circuit of cavity oscillator is equivalent to the common Colpitts oscillator.

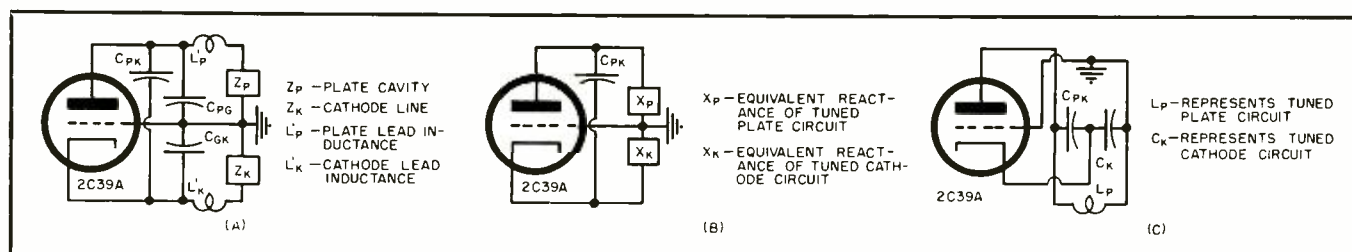

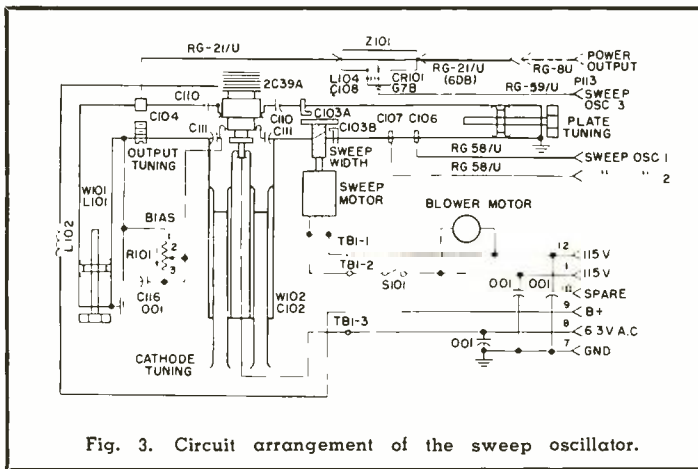

Fig. 3. Circuit arrangement of the sweep oscillator.

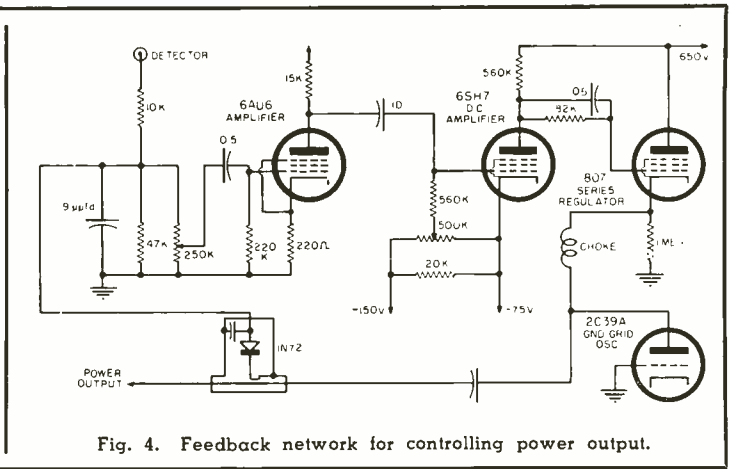

Fig. 4. Feedback network for controlling power output.

Details of a unit which has been found to be most satisfactory for testing u.h.f. transmitters, duplexers, and sideband filters.

elimination of the external feedback, necessarily meant a similar sacrifice in sweep flatness. In order to meet the design requirements, the sacrifice in sweep flatness was compensated for by employing inverse feedback control of the oscillator plate voltage. Figure 4 illustrates the voltage feedback network. An analysis of this circuit will show that an increase in power output of the cavity oscillator will cause a corresponding decrease of the oscillator voltage from its nominal value. The inverse will be true for a decrease in power output. Figure 5 illustrates the detected sweep envelope with and without feedback at 750 mc. and a sweep width of 12 mc.

To analyze the cavity, refer to Fig. 2, which shows that the progressive equivalent circuits for the cavity oscillator reduce to the common Colpitts oscillator in which the following required conditions have been met:

1. X_p and X_k are of opposite sign.
2. X_{pk} and X_k are alike.
3. X_k is less than X_p .

The plate cavity, tuned on the high side of the operating frequency, is represented by L_p and will primarily determine the frequency of oscillation. The cathode circuit, represented by C_k , is tuned on the lower side of the operating frequency and will have a relatively small effect on the oscillator frequency. However, C_k will determine the amount of voltage feedback required to sustain oscillation of the cavity since the feedback ratio C_k/C_{pk} will vary with adjustment of the cathode line.

It is worth noting that during development similar cavities were constructed of silver-plated brass and of aluminum. There was no apparent improvement in operation using the silver-plated brass; however, it was found

that tightness of joints was most important for optimum operation when using either silver-plated brass or aluminum.

The location of the components on the front and rear of the chassis, as called for on the schematic of Fig. 3, is shown in the photographs. For simplicity, manual adjustment of the 1% shorted cathode line and of the shorting bars in the plate cavity oscillator is used. During development of the cavity, an attempt was made to use a single geared tuning control for the plate shorting bars. However, this idea was discarded when it became evident that slots in the cavity radiated rather seriously and, also, the effect of running adjusting bars completely through the cavity was to reduce the output power considerably. It was found that the bars could extend well into the cavity from either side (Fig. 6) and not affect operation. This provided a means of adjusting the cavity over the u.h.f. band without going to an otherwise excessively large chassis.

Table 1 indicates the adjustment over the u.h.f. range of the separation of the plate shorting bars and of the shorted length of cathode line from the cavity wall. The cathode line changes from a one-quarter wavelength shorted line to a three-quarter wavelength shorted line at approximately 600 mc. Mechanical arrangement of the cathode tuning line places the short at one end of the adjustable stub. The stub may be completely removed and reversed, thus providing a tuning range almost twice as great as the actual length of the cathode tuning stub. This feature is illustrated schematically in Fig. 3.

In order to reduce loading effects on the cavity oscillator due to mismatch and load variations, 6.0 db of attenu-

ating cable is inserted between the oscillator output and the equipment being tested.

Variable sweep width is obtained by varying the capacitance of the cavity. A minimum sweep width of 12 mc. is possible over the u.h.f. frequency band. To vary the capacity of the cavity, an 1800-rpm synchronous motor is used to drive a capacitor plate located between two adjustable plates inside the cavity. Figure 6 illustrates the mechanical arrangement of these two plates. The capacitors are effectively in series across the cavity, thus requiring four times the capacity to sweep the cavity a given amount as a single variable capacitor. However, this method was arrived at only after considerable trouble was encountered in keeping r.f. energy from getting into the motor bearings when

Fig. 5. Detected sweep envelope without feedback (top) and with feedback (bottom) at 750 mc. Sweep width is 12 mc.

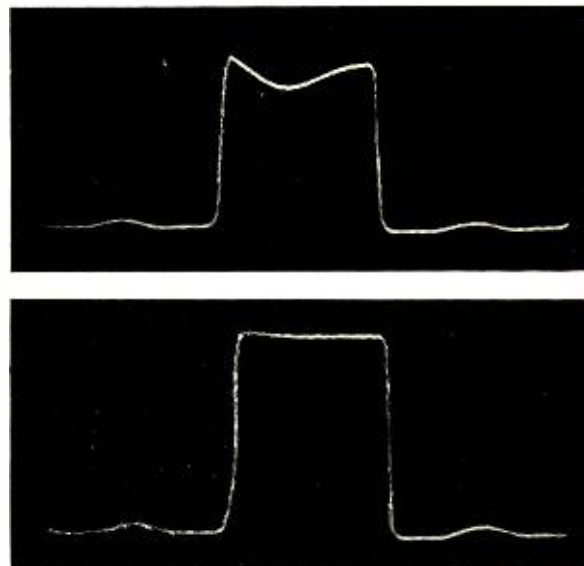

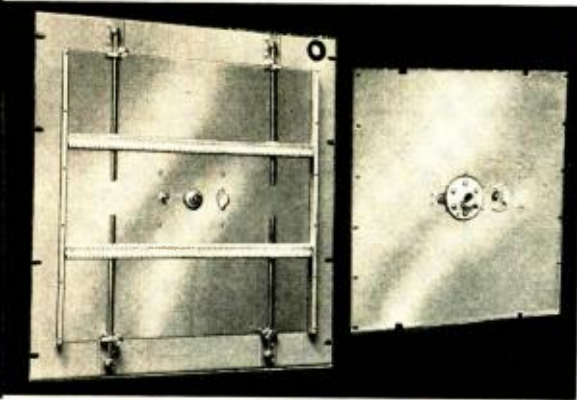

Fig. 6. Open view of the sweep cavity.

f (mc.)	L_c (inches)	L_p (inches)
500	2½	12½
600	11	9
700	8¾	6½
800	8	5
900	7½	4½

Table 1. Cavity dimensions. L_c = length of cathode line from cavity wall. L_p = separation between plate shorting bars.

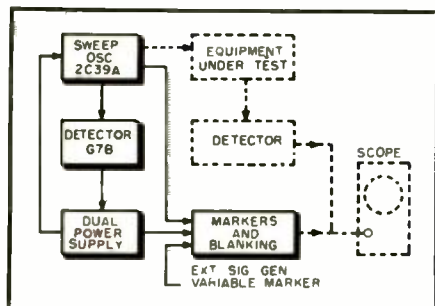

Fig. 7. Sweep generator system diagram.

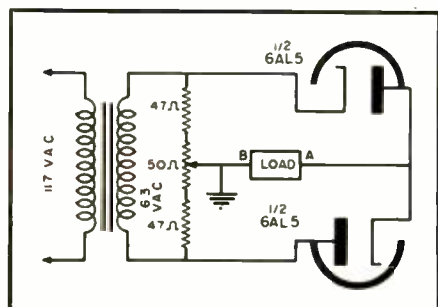
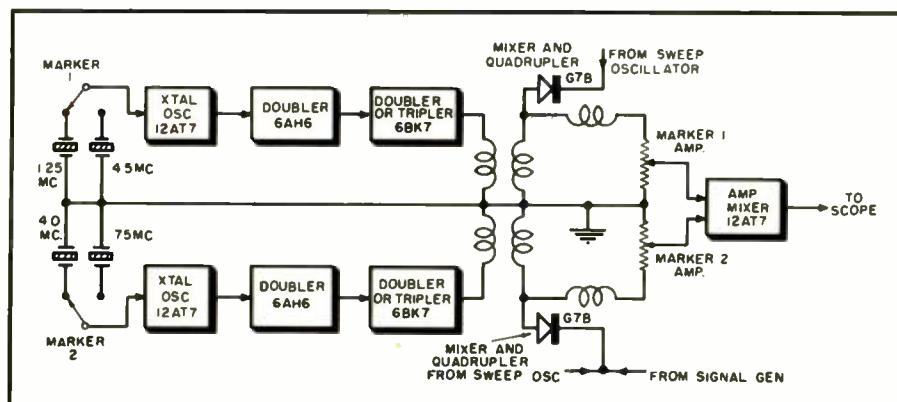

Fig. 8. Schematic of the blanking circuit.

Fig. 9. Block diagram showing basic elements of the marker generator.



using a single variable capacitor. The prior investigation employing a single capacitor across the cavity required that the rotating plate of the capacitor be returned to a good r.f. ground. If this ground were not effective, the r.f. energy would return to ground through the motor bearings and quickly deteriorate them. Efforts to obtain a good ground with an adjustable line choke were unsuccessful, as were attempts to ground the rotating shaft by means of spring fingers.

Using the 1800-rpm motor and a split stator capacitor, as indicated above, a dual trace will be obtained at a 60-cps rate and will consist of the forward sweep and the image or retrace sweep. In order to obtain a single pattern and to have a means of checking the amplitude with respect to a zero reference level, a blanking circuit has been incorporated into the sweep generator. Any effort to blank the signal by cutting off the oscillator will be ineffective, since the voltage feedback circuit employed to maintain the desired sweep flatness will tend to correct any blanking of the oscillator. Blanking is therefore applied to the envelope of the detected signal at the oscilloscope terminals together with the crystal markers, as illustrated in Fig. 7.

The blanking circuit employed (Fig. 8) is basically a double keyed diode clamping circuit in which the time constants have been eliminated and a filament transformer is used as a source of positive and negative clamping pulses. A study of the circuit will immediately show it to be similar to a Wheatstone bridge. Upon analysis, it becomes apparent that point "A" will be at ground potential when the 6AL5 conducts during the positive cycle. During the negative cycle, the 6AL5 is non-conducting and point "A" is at a high impedance to ground. The circuit is balanced by a 50-ohm potentiometer.

Marker Generator

A marker generator chassis employing crystal-controlled markers was developed for use with the sweep cavity oscil-

lator. Since the sweep generator was to be utilized in testing attenuating circuits as well as amplifier circuits, a method for mixing crystal marker pulses with the detecting envelope of the equipment being swept was selected such that the marker pulses would be easily distinguishable even if the marker frequency were highly attenuated in passing through the equipment being tested.

Production of the crystal marker pulses is independent of the equipment being tested; they are superimposed on the detected sweep envelope at the oscilloscope terminals. Each marker pulse is produced by beating a crystal-controlled frequency against the band of frequencies being swept through by the cavity oscillator. When the cavity oscillator sweeps past the crystal-controlled frequency, a band of frequencies is produced about a zero beat. This low range of frequencies is mixed and amplified with a similar beat effect from another crystal-controlled multiplier chain, as illustrated in Fig. 9. The plate circuit of the mixer amplifier stage employs a high Q coil which is self-resonant with the circuit capacity at approximately 50 kc. This resonant condition produces a visual marker in which the lower frequencies are removed.

Fundamental crystal frequencies are selected to provide markers at desired points on either side of the visual carrier. Although only two markers may be observed on the sweep envelope at a given time, a switch is provided which enables different marker frequencies to be switched into the oscillator circuit. The multiplier circuits following the crystal oscillator stage are sufficiently broad so that marker frequencies spaced within ± 6.0 mc. of the visual carrier may be inserted without retuning.

Although the u.h.f. sweep generator is easily aligned on any u.h.f. channel, the marker multiplier chains make the marker generator unit most adaptable for a given TV channel. However, an external u.h.f. signal generator may be used in parallel with either of the crystal-controlled multiplier chains, thus providing a variable marker over the u.h.f. band in addition to the two fixed crystal-controlled markers. The external signal generator is coupled into the same jack as the r.f. sweep signal, using a "T" connector. This additional adjustable marker is amplified in the same way as the crystal markers and is mixed with the blanking signal and the detected signal at the oscilloscope terminals.

As in any development of this sort, a great many individuals have contributed toward the end product. The work of William Fraser, the product design engineer on this project, is particularly appreciated.

connections simplified

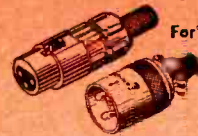

For low level sound applications.

Breakaway connector for instrument testing and control circuitry of guided missiles prior to launching.



For aircraft engine starting, commercial storage batteries, and stationary engine applications.

Sub-miniatures. Same number of contacts as in a standard connector, but in $\frac{1}{2}$ to $\frac{1}{3}$ the space.



Miniatures. For radio, control, instrument uses, etc.

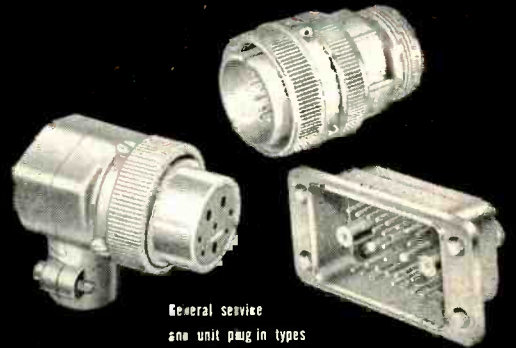

General service and unit plug in types



Hermetically sealed AN and K type connectors. Miniatures and sub-miniatures.



Special K connectors for TV cameras.



Water-tight and weather-proof connectors for rugged service.

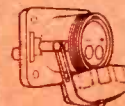

Heavy-duty AO type, originally designed for U.S. Army Ordnance. Adaptable to commercial use. Resilient insulation. Special assemblies.

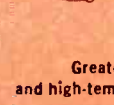

Greatest variety of firewall and high-temperature connectors.



Also—power plugs and receptacles for a wide range of applications.



first in connectors

CANNON PLUGS

Please refer to Dept. 401

CANNON ELECTRIC COMPANY,
3209 Humboldt Street, Los Angeles 31, California
Factories in Los Angeles, East Haven, Toronto, Canada;
London, England. Contact our representatives and
distributors in all principal cities of the U. S. A.

AUTOMATIC DUAL AM-FM MONITOR

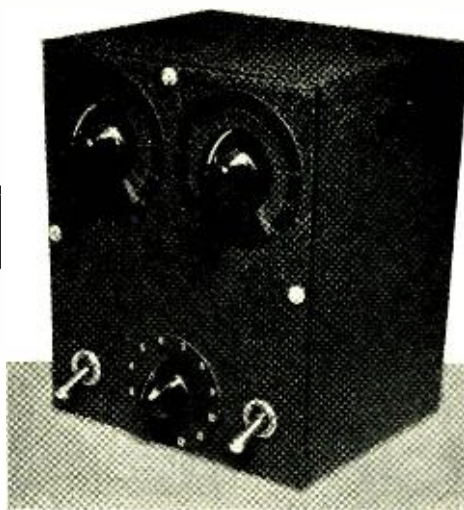

Front view of the complete unit.

By **HAROLD REED**

Consulting Radio Engineer

Automatic switching from one channel to the other takes place at periodic intervals.

SINCE the Federal Communications Commission amended its Rules and Regulations early in 1953, to permit remote control operation of AM and FM broadcast stations employing transmitters of 10 kw. or less and using non-directional antenna systems, many installations of remote control apparatus have been and are being made.

The FCC rules do not give specific procedures to be followed, nor do they specify the type of equipment to be incorporated into an installation. However, these rules do present specific standards that must always be met in the operation of such equipment. Therefore, remote control apparatus may be constructed by station engineers provided it will comply with the rules set forth by the FCC, or complete commercially manufactured equipment may be installed which will satisfy at least the minimum requirements of the FCC regulations.

There are a half dozen or so reliable manufacturers now producing remote control equipment, some of which do a little more than just meet FCC specifications. It has been observed, however, that there are features which—although not required by the FCC—are either necessary or desirable in connection with an installation of this type. One such feature is discussed in this article, and is especially important where remote control of more than one transmitter is being effected by a single technician either at the studio-control or other remote control location.

The arrangement outlined in the following paragraphs can be employed to provide monitoring facilities for an AM and FM broadcast transmitter, or other

combinations of transmitting facilities, remotely controlled by one technician and using a single speaker for the purpose. It was considered preferable, for various reasons, to use one speaker rather than two speakers continuously in operation from two individual sources. Breakdown in either transmission channel is not detected nearly as easily if the latter technique is used. Quality monitoring of two transmitters simultaneously radiating the same program on individual speakers would not be as thorough as monitoring each transmission in turn—especially when listening to a duplication of a program from both facilities, due to the very noticeable difference in response characteristics of the two channels.

Having decided on the desirability of one loudspeaker for this monitoring setup, two questions immediately arose: (1) how should the speaker be switched from one transmitter to the other, and (2) while one channel was being monitored, what method could be employed to provide indication that the other channel had not failed due to technical breakdown? For manual operation, the setup would be quite simple. But the control room technician is usually busily engaged in program switching and program level control, and would not always be able to give proper attention to this duty. Thus, one or the other of the broadcast channels might be neglected for considerable periods of time. Control by manual means would also introduce a nuisance factor. It was concluded, therefore, that the system would have to be automatic.

To satisfy the speaker switching function, a mechanical timer or motor-driven cam arrangement first came to mind; one of these devices could switch the single speaker to the two transmission channels alternately, thereby providing monitoring of each for a certain predetermined time interval. Either of these schemes would be entirely feasible, but it was considered desirable to avoid all mechanical apparatus other than relays. The problem was resolved when the idea of taking advantage of the very useful characteristics of a simple RC circuit presented itself, leading to an all-electronic device using a single relay.

Figure 1 shows the schematic diagram of a suitable circuit which includes a 12AT7 tube with the twin triode sections operating in parallel; many other types of tubes would, of course, be satisfactory. The relay in the plate circuit switches the two program sources, alternately, to the speaker monitoring amplifier. Two time constants are involved: the charging time interval of capacitor C_1 as determined by the product of R_1 and C_1 , and the discharging time of capacitor C_1 which is

(Continued on page 40)

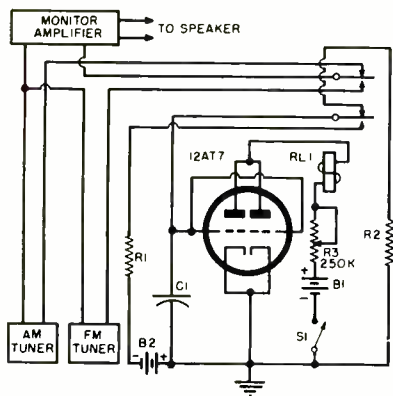

Fig. 1. Circuit for switching automatically from one channel to the other.

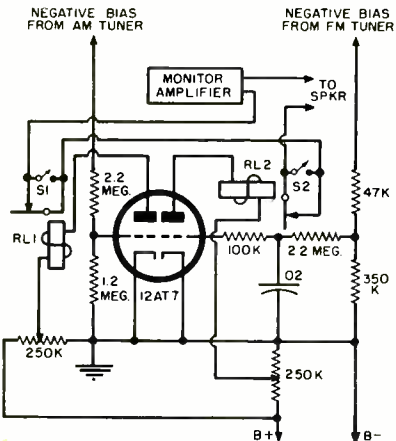
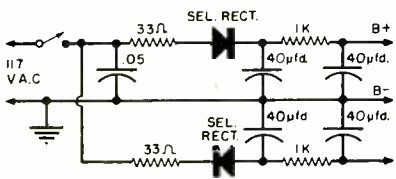

Fig. 2. Alarm system for indicating failure in channel not being monitored.

Fig. 3. Schematic of a power supply suitable for use with Figs. 1 and 2.



RCA OPENS NEW HORIZONS

in AVIATION ELECTRONICS!



ADVANCE THE SCIENCE OF

FIRE CONTROL • PRECISION NAVIGATION
COMMUNICATIONS

*You'll find challenge in: Systems, Analysis,
Development or Design Engineering*

And You Can Specialize In: Radar • Analog
Computers • Digital Computers • Servo-
Mechanisms • Shock & Vibration • Circuitry
• Heat Transfer • Remote Controls • Sub-
Miniaturization • Automatic Flight • Transis-
torization • Design for Automation

You Should Have: Four or more years' pro-
fessional experience and your degree in electrical
or mechanical engineering, or physics

You'll find unlimited opportunities for professional advancement in RCA's broadened aviation electronics program! Suburban or country living nearby. Relocation assistance available.

And at RCA, you'll move ahead through *learning* as well as *doing* . . . for RCA encourages you to take engineering *graduate* study with company-paid tuition. You'll also enjoy professional status . . . recognition for accomplishment . . . unexcelled facilities . . . *many* company-paid benefits.

Your RCA career can start now! Begin by sending a resume of your education and experience to: **Mr. John R. Weld, Employment Manager**
Dept. 304F, Radio Corporation of America
Camden 2, New Jersey



RADIO CORPORATION OF AMERICA

Tmks. ®

COMMUNICATION

REVIEW

NOISE MEASURING SET

As the result of a two-year research study sponsored by the U. S. Army Signal Corps, an instrument capable of measuring electronic noise and distortion in the frequency range from 100 kc. to 10 mc. has been developed by the Research Division of New York University's College of Engineering, University Heights, New York, N. Y. This tunable noise and distortion measuring set is expected to facilitate research, design, and maintenance of communications equipment in the lower portion of the r.f. spectrum.

The principal use of the instrument lies in the rapidly expanding field of multiplexing electronic equipment; it will enable researchers to measure signal-to-noise ratio per telephone channel, signal-to-crosstalk ratio per channel, and intermodulation distortion. Wide-band mean power and the power-frequency distribution of complex signals can now be determined with an accuracy of 1 db, and signal-to-crosstalk ratios as high as 60 db can be evaluated to within 3 db.

UNIVERSAL TWO-WAY RADIOS

Motorola Communications and Electronics, Inc., 4545 W. Augusta Blvd., Chicago, Ill., has announced a line of 144-174 mc., 10- and 25-watt FM mobile two-way radios. Known as the Universal Uni-Channel series, the new models operate interchangeably from either 6- or 12-volt automotive electrical systems



without any circuit modification whatsoever, and feature a patented long-life, dual-interrupter, all-vibrator power supply for both transmitter and receiver circuits.

Economy of maintenance and operation is keynoted in this series; tests have demonstrated vibrator life in excess of 1500 hours, and power drain during transmission is only 30 amperes at 6.3 volts or 15 amperes at 12.6 volts

—a drain roughly comparable to that of the average 10-watt mobile unit. Models are available for under-the-dash mounting with local controls and for trunk-mount installation with the microphone, control head and speaker installed near the driver.

SERVICE TRUCK SYSTEM

Faster emergency service for Central New York motorists has been made possible by the installation of two-way radio in six strategically located AAA emergency service trucks, and in the headquarters of the Automobile Club of Syracuse. Telephone requests from stranded motorists are received by this dispatcher and relayed by radio to the



nearest radio-equipped service truck. Supplied by the *General Electric Company*, this system eliminates the need for the service trucks to return to their garages in order to learn the destination of the next call.

MARINE RADIOTELEPHONE

"The Golden Courier" is a compact, lightweight and easily installed radiotelephone which has been introduced by *Radiomarine Corporation of America*, 75 Varick St., New York 13, N. Y. Known as the Model ET-8056, it has a golden anodized aluminum front panel and deep mahogany cabinet with protective finish.

Designed for use aboard small pleasure craft, a power rating of 35 watts also makes "The Golden Courier" applicable to larger boats. It can be used for ship-to-shore and ship-to-ship communication in the 2000-2800 kc. marine band as well as to receive entertainment programs in the standard 520-1650 kc. broadcast band. Other features include

an output indicator, a booster control and a noise limiter.

U.H.F. MOBILE RADIO SYSTEM

A complete mobile radio system designed for operation in the u.h.f. 450-470 mc. band is now available from the Mobile Communications Department of the *Allen B. Du Mont Laboratories, Inc.*, Clifton, N. J. Designated as the



Type MCA-401A, the system features many new developments in both electrical and mechanical design and includes all necessary installation accessories.

Type MCA-401A is rated at 12 watts at 450-460 mc. and 10 watts at 460-470 mc. The high-efficiency, plug-in power chassis requires minimum primary power, and a high degree of stability is maintained through the latest type of crystal oscillators. Economical operation is assured by the use of low-cost tube types, long-life selenium rectifiers, and other components of proved service records.

RADIO INTERFERENCE

Investigating and remedying radio interference has become one of the biggest jobs of Federal Communication Commission field engineers who operate under the Field Engineering and Monitoring Bureau. In addition to the 600,000-odd transmitters now authorized, the task is magnified by the accidental or careless release of emissions by a host of new devices and gadgets which use r.f. energy for various non-communication purposes—as well as television receivers. During the fiscal year 1953, the number of interference complaints requiring investigation approached 22,000, and the figure is still mounting.

As a result, the Commission has sought the cooperation not only of radio users but also of manufacturers, distributors and retailers of apparatus which can cause radio interference. It also tests and type-approves certain equipment in advance of manufacture to insure against interference when the apparatus is put in operation. In cases of wilful and reckless violation, it can resort to "show cause" orders or criminal proceedings.

How to prepare for

Color TV



The indispensable equipment guide for every TV Station planning color operations

What's in the Color Edition

- The RCA Color TV System
- What Color TV Means to the Broadcaster
- Television Transmitter Operation with Color Signals
- How to Plan for Color TV
- RCA Color Studio Camera, TK-40A
- RCA Color Slide Camera, TK-4A
- RCA Color Film Camera, TK-25A
- RCA 16mm Color Film Projector, TP-20A
- RCA Color TV Monitor, TM-10A
- RCA Colorplexer, TX-1A
- Test Equipment for Color Television
- RCA Color Sync Generator Equipment
- Video Amplifiers in Color Signal Transmission

THIS SPECIAL 80-page issue of RCA Broadcast News has been prepared specifically for the TV station man who is getting ready to work with color. Filled with authentic information not found in its entirety anywhere else, this issue includes important facts you'll want to know about color Now . . . such as general operating theory of the color telecast-

ing system, how to plan studios and stations for color, types of equipments and systems required, how to make equipment changeovers for color.

Copies of this special color issue of Broadcast News may be obtained from your RCA Broadcast Sales Representative. Or write Section 503, RCA Engineering Products, Camden, New Jersey.

The only 100% engineering-operations journal for station men



Read by broadcasters and telecasters longer than any technical magazine of its kind in the industry, RCA BROADCAST NEWS is prepared specifically to keep station men up-to-date on equipment-and-station operations. It includes straight-to-the-point facts on planning installations, testing and operating station equipment—newsy stories about stations from the stations themselves—interesting articles on “how-it-works” and “how-to-do-it” for the everyday job—plus equipment information you can find in no other periodical. RCA BROADCAST NEWS is published every other month. Ask your RCA Broadcast Representative to put you on the list to receive it regularly.



RADIO CORPORATION of AMERICA
ENGINEERING PRODUCTS DIVISION
CAMDEN, N. J.

NEW PRODUCTS

ULTRASONIC DELAY LINES

Solid ultrasonic delay lines manufactured by the *Bliley Electric Company*, Union Station Building, Erie, Pa., provide precise delay intervals for electronic equipment: Type SDL-15, 1000



yards, 3.051 μ sec. (shown in photograph); Type SDL-16, 2000 yards, 6.102 μ sec. Carrier frequency is 30 mc., attenuation 26 db into 1000 ohms, and the bandwidth is 8 mc. Each unit is enclosed in a hermetically sealed case and is available immediately from production.

ALARM SYSTEM

An alarm system that reports any malfunction in unattended operation of equipment and warns of breakdowns of remote control telemetering apparatus is now available from the *Hammarlund Manufacturing Company*, 460 West 34th St., New York 1, N. Y. Power failure, excessive temperatures, fire, failure of control equipment, abnormal system conditions, unauthorized entry, and automatic transfer to standby equipment may all be quickly brought to the attention of supervisory personnel at central control points.

The basic alarm system consists of a battery-powered tone transmitter and a

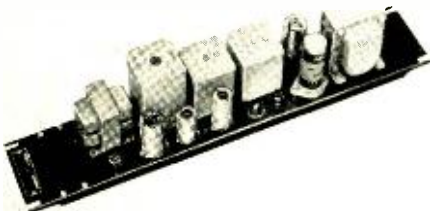

frequency selective receiver with a suitable alarm display. Information is transferred from transmitter to receiver either as a continuous 1000-cycle

audio tone or as an interrupted 1000-cycle tone, depending on the coverage required and the degree to which the character of failure must be identified.

TELEMETER PACKAGES

When used with power supply and r.f. transmitter, the two telemeter packages incorporating plug-in subcarrier oscillators which have been announced by the Pacific Division of *Bendix Aviation Corporation* provide a compact, rugged FM/FM system for telemetering many functions. The units are cubical in shape, measuring approximately 4½" in each dimension, and may be combined to form an 8- or 12-

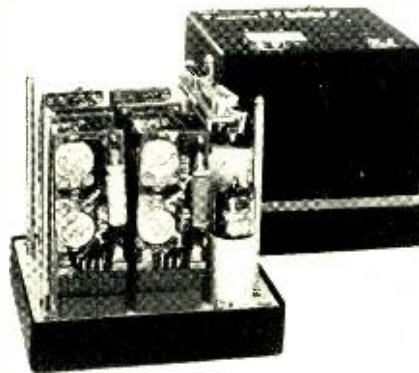

band system. Oscillators are mounted vertically in the containers, and each package contains its own voltage regulator and calibration relays.

One of the new packages is designated as Model TATP-3 and operates in any four of the rdb bands below 22 kc. Model TATP-4 operates in any of the bands from 22 kc. up. Technical data sheets on these telemeter packages are available from Pacific Division, *Bendix Aviation Corporation*, 11600 Sherman Way, N. Hollywood, Calif.

L-BAND SLOTTED LINE

Model SL-28 L-band slotted line can be a valuable laboratory instrument for those working in the region between 1120 and 1740 mc. Announced by *Press Wireless Laboratories, Inc.*, the unit measures the voltage standing wave ratio in Type RG-69/U, RG-103/U and other wave guides of equal dimensions (6½" x 3¼"). From the standing wave pattern, the amount of mismatch between line and load may be accurately

determined, the impedance of the load can be obtained, and the wavelength may be measured directly.

This slotted line mates with UG-417/U and UG-418/U flanges. The scale is calibrated from 22 to 54 cm., and may be read to within 0.01 cm. Residual

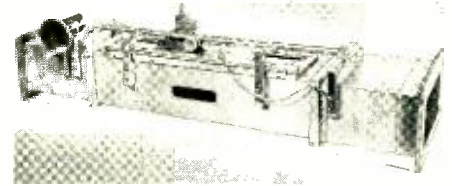

VSWR is less than 1.05 with probe at maximum insertion. For further information, contact Mr. Norman F. Hoard, *Press Wireless Laboratories, Inc.*, 25 Prospect Place, W. Newton 65, Mass.

MICROWAVE FREQUENCY METER

NARDA—Nassau Research & Development Associates, Inc., Mineola, N. Y., has developed a laboratory-type frequency meter with a range of 8200 to 12,400 mc. for use in the X-band region. Features include: high Q , an accuracy of 0.1%, ease of tuning, calibration chart mounted on cavity, and a large reactive dip for rapid location of resonance.

Model 810 consists of a resonant cavity in the TE_{11} mode, tunable by varying the cavity length with a noncontacting shorting plunger. The cavity is mounted on a short length of 1" x ½" wave guide which is terminated in UG-39/U cover flanges.

HARMONIC WAVE ANALYZER

For continuous coverage of the frequency region from 50 cps to 50 kc., the *Donner Model 20* harmonic wave

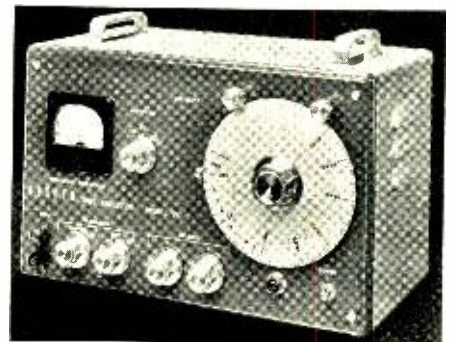

analyzer combines small size, light weight and low cost with high accuracy and sensitivity. A 1% second harmonic of 100 cps may be measured on this instrument with 5% accuracy. Good selectivity is achieved with a double half-lattice crystal filter which provides 3-db attenuation at 14 cps and 40-db attenuation at 75 cps off resonance.

The output meter of the Model 20 can be readily adjusted to 100% reading for

any input voltage between 50 mv. and 500 volts. Internal voltage regulation preserves accuracy with line voltage variations up to -10%. Full details are contained in Technical Bulletin No. 201, available on request from the *Donner Scientific Company*, 2829 Seventh St., Berkeley 10, Calif.

MICROWAVE ROTARY JOINT

Exceptional operating characteristics are offered in the high power microwave rotary joint which has been announced by *Microwave Development Laboratories, Inc.* Model B 172a has the following characteristics: wave guide—RG-51/U; peak power—200 kw.; VSWR— ≤ 1.2 —8.2-10.0 kmc.; ≤ 1.1 —8.5-9.6 kmc. The design is such that the variation in VSWR and phase shift with rotation is negligible (of the order of 1.02 or

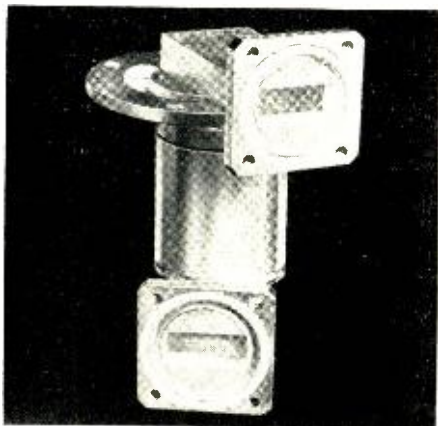

$\pm 2^\circ$). It is pressurized from -55 to 70°C and may be rotated with a torque of 5 inch-pounds.

Write to *Microwave Development Laboratories, Inc.*, 200 Grove St., Waltham 54, Mass., for complete catalog information on this new high power rotary joint.

TV COLOR CAMERA

With the *RCA* "3-V" color camera for televising motion picture film and slides, many broadcasters will be able to use present black-and-white film and slide projectors with only minor modification; equally important, they can use a single 3-V camera to select up to three picture sources and shift from one to another simply and instantaneously. Employing three vidicon pickup tubes and a light-splitting optical system of dichroic mirrors, this camera supersedes all other *RCA* color film and slide methods.

The new camera will be used with a special 3-V optical multiplexer, also being placed in production by *Radio Corporation of America*, Camden, N. J. Into this unit may be fed the output of two motion picture projectors—either 16 mm. or 35 mm.—and a dual-disc, single-lens, 2" x 2" slide projector. Controls on
(Continued on page 42)

By the Push of a Button!
...in just 0.8 seconds your contact is made...

**...WHEN YOU ADD HAMMARLUND
Selective Calling Equipment
to Mobile 2-Way Radio Systems
...AND it means**

PRIVACY...QUIETNESS...CONVENIENCE

Privacy, speed, quietness and convenience become an accepted part of day-in-day-out operations of 2-way radio systems used to control large fleets of emergency service or commercial vehicles, or distant fixed stations, when Hammarlund Selective Calling Equipment is added.

By the push of a button the dispatcher selects within 0.8 seconds the vehicle, remote station, or group of receivers which he wants to contact. Only the *selected* operator or group of operators can receive the call.

If a radio operator is away from

his station when a call comes in, an indicator light will be turned on to show he was called while absent. For police and other emergency vehicles the horn or other alarm can be remotely activated to summon drivers whose work has taken them from the immediate vicinity of their cars.

Write today to the Hammarlund Manufacturing Company for descriptive information about this selective calling equipment that was engineered to produce new benefits for you from your 2-way radio system. Ask for Bulletin R-6.

 **HAMMARLUND**

HAMMARLUND MANUFACTURING CO., INC.
460 WEST 34th ST. • NEW YORK 1, N. Y.

TECHNICAL BOOKS

"APPLIED ELECTRONICS" by Truman S. Gray, Associate Professor of Engineering Electronics, Massachusetts Institute of Technology. Second Edition. Published by *The Technology Press*, M.I.T., and *John Wiley & Sons, Inc.*, 440 Fourth Ave., New York 16, N. Y. 881 pages. \$9.00.

New devices, principles and methods of analysis have greatly extended the possibilities for the application of electronics. However, the basic pattern of the field, and hence of this book, remains essentially unchanged. In bringing the coverage up to date, the aim has been to lay a foundation for effective engineering application of basic phenomena. "Applied Electronics" is intended as a first course in electronics, electron tubes, and associated circuits.

Divided into four main parts, this book discusses the physical phenomena involved in electronic apparatus, explains the way in which these phenomena combine to govern characteristics, ratings and limitations of electronic devices, considers applications common to the several branches of electrical engineering, and provides a treatment of semiconductor devices—primarily the transistor.

"MAGNETIC-AMPLIFIER CIRCUITS—Basic Principles, Characteristics and Applications" by William A. Geyger, Magnetics Division, U. S. Naval Ordnance Laboratory. Published by *McGraw-Hill Book Company, Inc.*, 330 West 42nd St., New York 36, N. Y. 277 pages. \$6.00.

Here is a practical exposition of the fundamental principles and applications of magnetic amplifiers with special reference to servo amplifiers. It develops logically the various kinds of basic and more complicated circuit arrangements, and represents a source of detailed information for engineers, teachers and students. Emphasis is placed on experimentally observed phenomena; descriptive and graphical methods are used to give a qualitative and quantitative interpretation of essential facts.

The contents include: classification of saturable-core devices and a brief history of magnetic amplifiers; description of core materials, core construction, winding arrangements, and rectifier devices; a systematic presentation (Chapters 3 to 16) of the numerous types of circuits; and a discussion of the technical properties, transient response and typical applications of magnetic amplifiers.

continuous un-interrupted Micro Wave operation with "US" MICRO-POWER

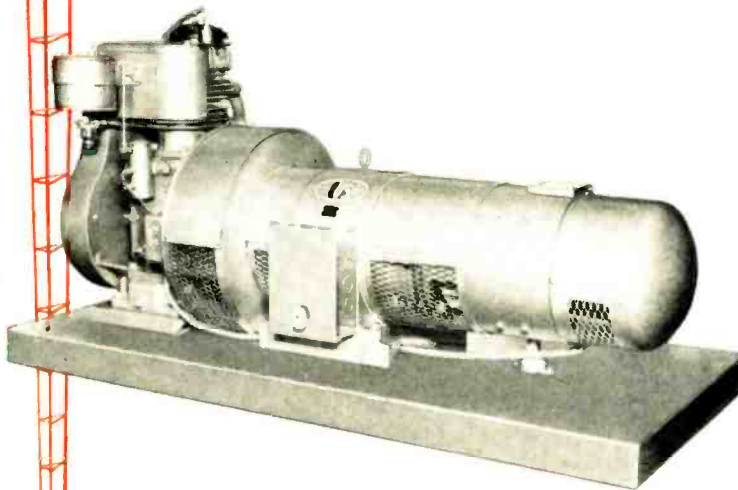

A single relay in your Micro Wave System stops functioning... what happens until service is restored? That break may be but a matter of seconds... but think of the amount of equipment you must maintain... to minimize such interruptions!

Now MICRO-POWER... ELIMINATES all the hazards of POWER OUTAGES! MICRO-POWER provides CONTINUOUS power for UN-INTERRUPTED micro wave operation!

AND WHAT'S MORE... Micro-Power does it WITHOUT costly investment in standby electric plants, battery banks, rectifiers and motor generator sets.

IN NEW installations, Micro-Power can save up to \$300 per mile! INVESTIGATE MICRO-POWER. Write "U.S." for complete details... or ask your supplier of Communication equipment... INSIST on U.S. MICRO-POWER in your next micro wave installation.



UNITED STATES MOTORS CORPORATION

551 Nebraska Street
OSHKOSH, WISCONSIN

trifles make **PERFECTION...**
but **PERFECTION** *is no trifle*

±1 IN A
 SERIES OF
 TREMENDOUS
 TRIFLES

*3½ ounces
 of
 perfection*

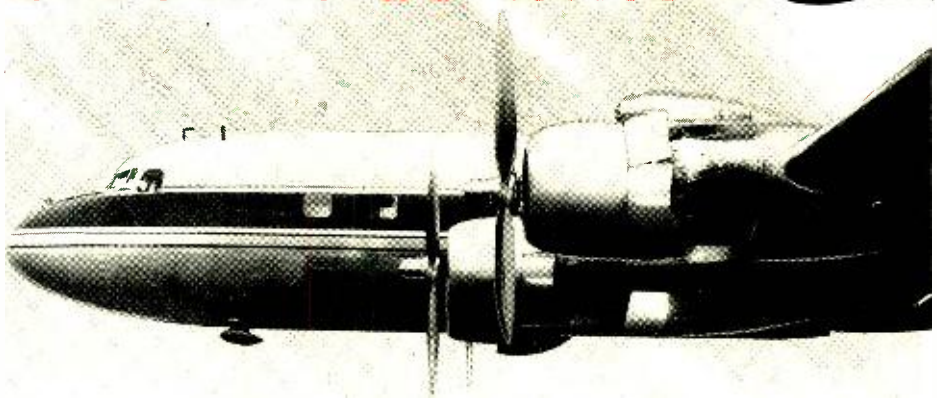

is **VITAL to 61 TONS of MAGNIFICENT
 PERFORMANCE**

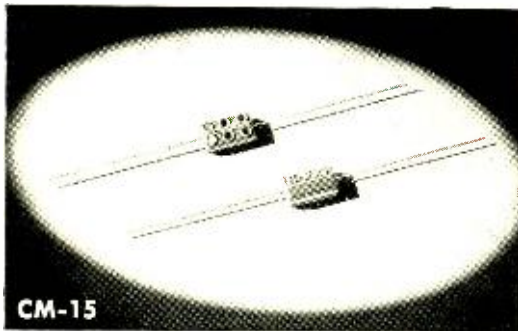

CM-15
 Smallest Molded Mica Capacitors 9/32" x 1/2" x 3/16"

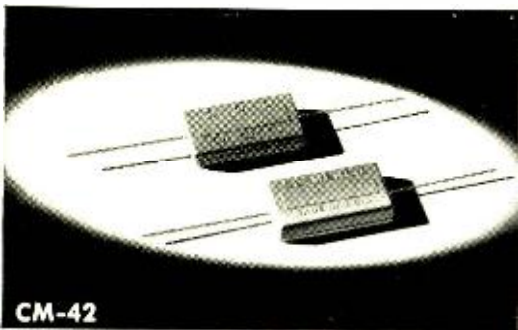

CM-42
 Made to Meet All MIL-C-5 Requirements. Largest Molded Mica Capacitors of Wire Terminal Type. 13/16" x 1-1/2" x 5/16"

When the mighty giants of the air lift their massive wings to fly, a thousand and more "tremendous trifles" instantly go to work in harmonious unison to give life and power. It is the perfection of these "trifles" that makes possible the magnificent performance of today's luxurious air liners.

The EL MENC0 Capacitor—CM-15—is one of these "tremendous trifles" that plays such a vital part in the efficient operation of aircraft communication.

EL MENC0 IS THE ONE OUT OF MANY CHOSEN FIRST
 Superiority of manufacture and dependability of performance make EL MENC0 first choice on the specification sheet . . . because EL MENC0 Capacitors are factory-tested at *double their working voltage* — they are *guaranteed stable* under the most adverse conditions. Whether you use our *high capacity* CM-42 (10-25,000 mmf) or our midget *low capacity* CM-15 (2-525 mmf) you have guaranteed assurance of job-tested, job-rated capacitors — tremendous trifles of perfection so vital to the magnificent performance of YOUR product.

ELECTRO MOTIVE is now supplying special silvered mica films for the electronic and communication industries — just send us your specifications.

Jobbers and Distributors are requested to write for information to Arco Electronics, Inc., 103 Lafayette St., New York, N. Y. — large stocks on hand — spot shipments for immediate delivery. Sole Agent for Jobbers and Distributors in U. S. and Canada.

WRITE FOR FREE
 SAMPLES AND
 CATALOG ON
 YOUR FIRM'S
 LETTERHEAD

MOLDED MICA

EL-Menc0
CAPACITORS

MICA TRIMMER



Foreign Electronic Manufacturers Get Information Direct from our Export Dept. at Willimantic, Conn.

THE ELECTRO MOTIVE MFG. CO., INC.

WILLIMANTIC, CONNECTICUT



SHIFT REGISTER

Known as a shift register, the tiny plastic case being demonstrated here contains 16 transistors and other com-



plex components and circuits that enable it to function as the "memory" of an electronic computer. This unit, which was displayed by *Sylvania Electric*

Products Inc., 1740 Broadway, New York, 19, N. Y., at the IRE Convention in March, stores and "remembers" figures to which the computer will refer during various stages of a computation.

INCREASING DIODE STABILITY

Stability and life of germanium diodes are expected to be greatly increased by means of a manufacturing process developed by *Sylvania Electric Products Inc.*, 1740 Broadway, New York 19, N. Y. *Sylvania* will add the new process to its entire line of hermetically sealed diodes, retaining the same specifications and type numbers.

The rectifying action of a germanium diode is accomplished by a barrier which is formed at the time the diode is made and which gives it the desired characteristics. Diodes made in the past have occasionally developed a second barrier on the surface of the germanium electrically opposed to the origi-

nal one, resulting in unstable operation. The new process will serve to lock in permanently the characteristics that are initially built into the diodes.

MONITORING BROADCASTS

How Station WTMJ, Milwaukee, Wis., keeps an air check of all shows going out over the airwaves is shown in



this photograph. Broadcasts are monitored on an Audograph furnished by *The Gray Manufacturing Company*, 521 Fifth Ave., New York, N. Y. The tough, paper-thin plastic disc records a full half-hour show on each side clearly and economically. One hundred hours of broadcasting can be permanently recorded and filed in a box only 1½" deep and 9" square.

ELECTRONIC POWER SWITCH

A RELATIVELY transient-free externally triggered electronic power switch has been devised by J. Sargent of the National Bureau of Standards. The output waveform of this switch has rise and cutoff times of less than one microsecond. Over a frequency range from zero to 10,000 cps, the "time-on" interval can be varied from 1 μsec. to a maximum of about 50 μsec. less than the repetitive period.

This electronic switch utilizes three tubes—two thyratrons and a diode rectifier. A capacitor is connected to the plate of the power-delivering thyatron through the diode, and to the plate of the turn-off thyatron through an inductance. The other side of the capacitor is returned to ground. When the circuit is in use, the capacitor is normally in a charged state. Output voltage appears across the cathode of the power tube.

The switch is turned on in the usual way by applying a pulse to the grid of

the power tube. When the circuit is to be turned off, a pulse is applied to the grid of the turn-off tube, which then begins to conduct and discharges the capacitor through the inductance. The LC series circuit provides an oscillatory discharge whose frequency is determined by the capacitor and the inductance. However, the thyatron conducts in but one direction; although current flows for only one-quarter of a cycle, this is sufficient time to discharge the capacitor completely. The rapidly decreasing voltage of the capacitor appears on the plate of the power thyatron, thereby cutting off the flow of current through the tube and at the same time extinguishing the turn-off tube. After the thyratrons have deionized and the capacitor has become recharged, the cycle may be repeated.

An experimental model of this circuit, built at the Bureau, is capable of delivering 50 watts into a 200-ohm resistive load, at as much as a 95% duty factor or as low as desired. Leading and trailing edges of the output rectangular waveform are less than 0.25 μsec.; and when the switch is pulsed on or off, there is no appreciable distortion from transient voltages.

Flexibility in design of the NBS electronic power switch is possible with the large variety of thyratrons available. The circuit may be readily adapted for a wide range of applications.

Circuit of the power switch.

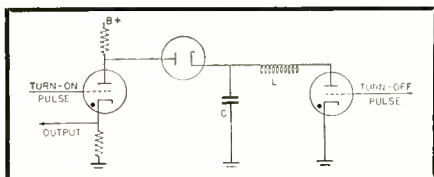

specially designed weighing platforms and toll recorders that is expected to result in greater operating efficiency, increased revenue protection and more equitable vehicle classification.

As each vehicle approaches the turnpike entrance toll booth, it will pass over a weighing platform located across the width of the traffic lane where it

will be automatically weighed while in motion and without delaying traffic. The vehicle weight class and other information will then be punched into the toll ticket as it is validated by the toll recorder shown in the photograph.

THOMPSON EXPANDS

The purchase of *Dage Electronics Corporation*, Beach Grove, Ind., producer of TV cameras and related equipment, has been announced by *Thompson Products, Inc.*, Cleveland, Ohio, manufacturer of aircraft, automotive and electronics parts, thus marking *Thompson's* entry into an entirely new field. Operating as a decentralized unit of *Thompson's* Electronics Division, the *Dage* assembly plant will continue in its present location near Indianapolis; no changes in personnel are contemplated.

HIGH VACUUM PUMP

A simple experimental air pump with no moving parts that can produce a vacuum as high as one billionth of normal atmospheric pressure has been built by Dr. A. M. Gurewitsch and Dr. W. F. Westendorp, at the Research Laboratory of the *General Electric Company*, Schenectady 5, N. Y. Known as an ionic pump, the device may eventually simplify exhaustion of radio tubes



and other widely used vacuum tubes in the process of manufacture.

One form of the pump consists of a circular stainless steel box, about 2" in diameter and 1" thick, supported between the poles of a powerful Alnico permanent magnet and connected by means of a tube to the vessel from which gas is to be exhausted. Electrical forces break up the gas atoms and hurl the fragments into carbon plates at the sides of the pump, where they stick, so that the gas is gradually removed and the desired vacuum is reached. In the photograph, Dr. Gurewitsch is shown adjusting the magnet.



Another First for

CHICAGO

The complete **MS** (Military Standard) line of Hermetically-Sealed Power & Filament Transformers

CHICAGO TRANSFORMER now offers all units in the Military Standard (MS) line, as established jointly by the three armed forces (Army Signal Corps, Navy Bureau of Ships, and Air Force) working through ASES (Armed Services Electronic Standards Agency) and in cooperation with the transformer industry. The complete line is housed in CHICAGO's one-piece drawn-steel cases. Outside case dimensions and mounting dimensions are within the tolerances of the Military Standard specification. Terminal arrangements and markings are also in accordance with the same specification. Tests conducted in the CHICAGO TRANSFORMER laboratories indicate that all units will meet the requirements of Grade 1, MIL-T-27 specifications for Class A operation. The Military Standard line should find wide usage in military airborne, marine, and ground communication equipment, and particularly for research and development applications, pilot runs and pre-production models.

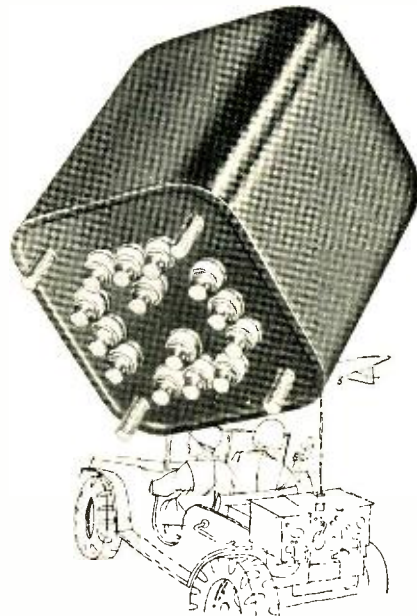

POWER TRANSFORMERS—INPUT REACTOR SYSTEMS (PRIMARY—105/115/125 V.—Frequency 54-66 cycles)

CATALOG NUMBER	MIL-T-27 PART NO.	HIGH VOLTAGE A-C Volts	SECONDARY D-C MA.	D-C V OUTPUT	RECT. FIL. Volts	FIL. Amps.	FIL. NO. 2 Volts	Amps.	WT. LBS.
PMS-70	MS-90026	200-100-0-100-200	70	385	6.3/5	2	6.3	3	4
PMS-70A	MS-90027	325-0-325	70	260	6.3/5	2	6.3	4	5
PMS-150	MS-90028	325-0-325	150	245	6.3	5	5	3	7 1/4
PMS-175	MS-90029	400-0-400	175	318	5	3	6.3	8	10
PMS-250	MS-90030	450-0-450	250	345	5	3	6.3	8	13
PMS-350	MS-90031	350-0-350	250	255					7 1/2
PMS-550	MS-90032	550-0-550	250	419					11
PMS-800	MS-90036	800-0-800	250	640					16 1/2

FILAMENT TRANSFORMERS (PRIMARY:—105/115/125 V.—Frequency 54-66 cycles)

CATALOG NUMBER	MIL-T-27 PART NO.	SECONDARY Volts	Amps	INSULATION VOLTS RMS	WT. LBS.
FMS-23	MS-90016	2.5	3.0	2500	1 1/2
FMS-210	MS-90017	2.5	10	2500	2 1/2
FMS-53	MS-90018	5.0	3.0	2500	1 3/4
FMS-510	MS-90019	5.0	10	2500	4
FMS-62	MS-90020	6.3	2.0	2500	1 3/4
FMS-65	MS-90021	6.3	5.0	2500	2 3/4
FMS-610	MS-90022	6.3 CT	10	2500	5
FMS-620	MS-90023	6.3	20	2500	8
FMS-210H	MS-90024	2.5	10	10000	4 3/4
FMS-510H	MS-90025	5.0	10	10000	7



Free "New Equipment" Catalog

You'll also want the full details on CHICAGO'S New Equipment Line of famous "Sealed-in-Steel" Transformers. Write for Free Catalog CT-153 today, or get it from your electronic parts distributor.



CHICAGO STANDARD TRANSFORMER CORP.

3501 W. ADDISON ST., CHICAGO 18, ILL.

NEW LITERATURE

INSTRUMENT BUYERS' GUIDE

The availability of a comprehensive buyers' guide of instruments and controls has been announced by the *Electro-Tech Equipment Company*, an organization which specializes exclusively in distribution and servicing of such equipment. Electrical meters, special industrial controls and electrical test equipment being distributed for over 90 manufacturers are covered in 189 pages of equipment items.

Instruments Catalog No. 54, as well as an engineering consultation service, will be supplied free of charge upon request to *Electro-Tech Equipment Company*, 208 Canal St., New York 13, N. Y.

POWER TUBES

In a 12-page booklet, the *Westinghouse Electric Corporation* has made available a complete guide on "Reliatron" power tubes. Characteristics and ratings of over 150 tube types are contained in Booklet 86-020, copies of which may be secured for 15 cents each from the Electronic Tube Division, Dept. T-056, Box 284, Elmira, N. Y.

All types of rectifiers, phototubes, amplifiers, modulators, oscillators and

other miscellaneous types are described, and an interchangeability chart lists the *Westinghouse* type that directly replaces each of approximately 225 tubes of other manufacturers.

SELENIUM RECTIFIERS

A 74-page handbook on selenium rectifiers has been compiled by the Rectifier Division of *Sarkes Tarzian, Inc.*, 415 N. College Ave., Bloomington, Ind., which is available for \$1 a copy. It is divided into seven complete sections: (1) "Centre-Seal'd" power rectifiers, (2) high voltage selenium rectifiers, (3) embedded selenium rectifiers, (4) "Centre-Kooled" radio and television rectifiers, (5) applications, (6) engineering data, and (7) a selenium rectifier replacement guide.

SHIELDED ENCLOSURES

"Evaluating Shielded Enclosures" is the title of an engineering study by Richard B. Schulz which has just been published by *Ace Engineering and Machine Co.*, 3644 N. Lawrence St., Philadelphia 40, Pa., in the form of a 16-page booklet. The first of its kind, this booklet reduces the major factors in-

involved in shielded enclosure specifications to their basic engineering equivalents, then compares and evaluates them.

INFORMATION STORAGE

Logistics Research, Inc., has issued a four-page illustrated pamphlet which describes in detail a new method of electronic information storage. Called the "Magnetic Library System," the *LRI* innovation consists of an electronic digital computer and a memory wheel working in conjunction with commonly used office machines.

The pamphlet describes the technical functions of the "Magnetic Library System" and outlines its practical application. Copies may be obtained from *Logistics Research, Inc.*, 141 S. Pacific Ave., Redondo Beach, Calif.

BALANCED MIXER DESIGN

Basic theoretical and design information needed by the radar or commercial microwave relay engineer in choosing the proper wave guide mixer for his particular application is provided in Technical Bulletin T-2600. In addition, the construction, operating characteristics and applications of *Airtron* types of balanced mixers are described.

Copies of Technical Bulletin T-2600 may be obtained without charge by writing to Dept. A, *Airtron, Inc.*, 1103 W. Elizabeth Ave., Linden, N. J.

INK-WRITING GALVANOMETERS

Characteristics and features of the *Edin* line of ink-writing galvanometers for research and industrial instrumentation are outlined in considerable detail in Bulletin B-1, available on request from *Edin Co., Inc.*, 207 Main St., Worcester 8, Mass. Specifications are given for eight different models.

MEASURING DEVICES

Measuring, indicating, recording and controlling devices for use in many different industries are covered in an eight-page, two-color folder published by *Schaevitz Engineering*, P. O. Box 505, Camden 1, N. J. Included are descriptions and illustrations of linear and angular accelerometers, linear variable differential transformers, rotary variable differential transformers, pressure transducers and rotary accelerators.

MICROWAVE TUBES

Data on microwave design practice, new tubes and improvements to standard tubes are contained in Catalog 54T, released by *Microwave Associates, Inc.*

(Continued on page 33)

TV-AM-FM SET PRODUCTION

Information based on latest reports from RETMA.

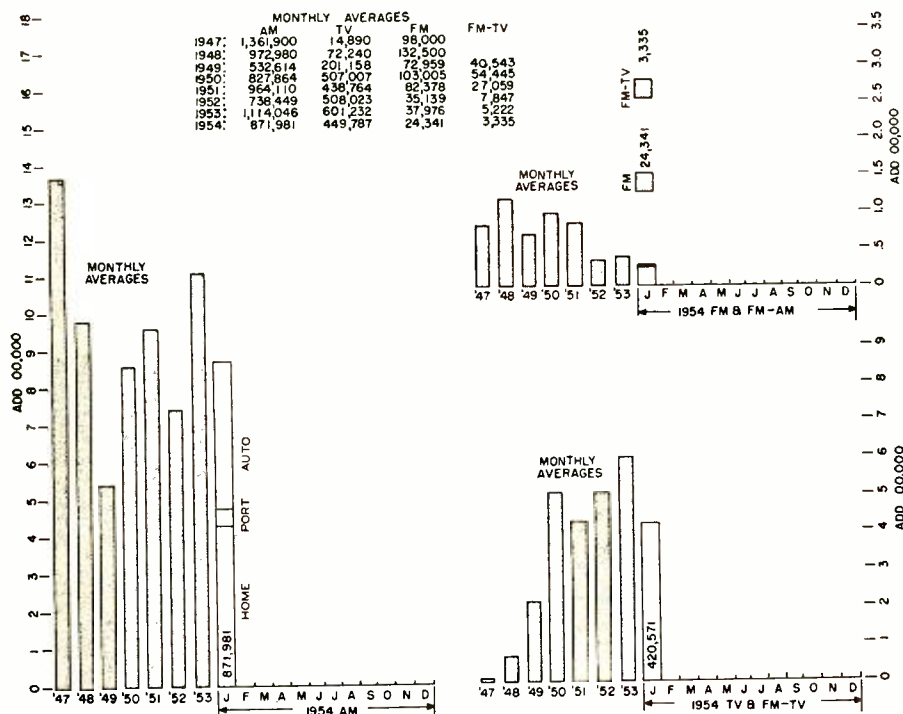

Air Sea Rescue?



The loss of one ship just over a year ago also cost more than 100 lives. The disaster occurred only 20 miles from land but search aircraft found the location too late because there was no ship-to-air communication. Further tragedies may well be avoided by ships being able to talk direct to each other and to aircraft. The RM.200 V.H.F. transmitter and receiver has been developed to meet this need.



TYPE RM.200 Multi-spot channel marine V.H.F. radio-telephone operating from A.C. Mains and/or Batteries. Amplitude Modulation.

Range: Ship-to-ship 25 miles; Ship-to-air over 100 miles.

Provides communication on the following INTERNATIONAL channels and 8 other channels.

121.5 Mc/s Aircraft Distress & Safety

156.3 Mc/s Marine Intership

156.6 Mc/s Marine Port Control

156.8 Mc/s Marine Safety & Calling



REES MACE MARINE LTD.

... ONE OF THE  GROUP OF COMPANIES

Personals

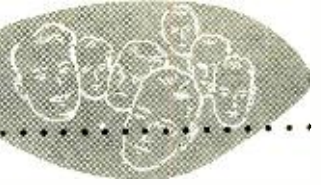

Industry
"Workhorse"

635

**BROADCAST
DYNAMIC
MICROPHONE**

USED ON

**TV
AND
BC**



Uniform high quality performance day-after-day in studio and remote pick-ups has proved the rugged dependability of the "635".

Exclusive E-V Acoustalloy diaphragm assures smooth, peak-free response 40-15,000 cps. Output is -55 db. 50-250 ohms impedance selector. Tilttable head. 5/8"-27 thread. Cannon XL-3 connector. 18 ft. cable.

List Price \$75.00

Normal trade discount applies.

See your Authorized E-V Distributor or Write for further information.

NO FINER CHOICE THAN

Electro-Voice
BUCHANAN • MICHIGAN



LEONARD A. BAYER has been appointed to the new position of manager of the Product Engineering Department of the Communication Products Division, *Allen B. Du Mont Laboratories, Inc.*, Clifton, N. J., to coordinate the translation of product designs into equipment ready for mass production. Mr. Bayer's 18 years of engineering experience have included 12 years in the television and radio fields; he joined the *Du Mont* organization in 1946.



DR. FREDERICK W. BROWN, as director of the Boulder (Colorado) Laboratories of the National Bureau of Standards, will be in charge of the research, development and standards programs of the NBS Central Radio Propagation Laboratory and the NBS-AEC Cryogenics Engineering Laboratory. An outstanding administrator of scientific research, Dr. Brown has been serving as technical director of the Naval Ordnance Test Station at China Lake, Calif., since 1951.



FRANK A. COWAN, assistant director of operations, Long Lines Department, *American Telephone & Telegraph Company*, has been awarded the AIEE Lamme Gold Medal for 1953 "for his outstanding contributions to long distance communication and the development of modulating and transmission measuring apparatus of original design and application." Holder of 17 patents in the field, Mr. Cowan is the first telephone engineer to receive this medal.



DR. KENNETH H. KINGDON will be the manager of the new Nucleonics and Radiation Section of the *General Electric* Research Laboratory at Schenectady, N. Y. With *G-E* since 1920, Dr. Kingdon was one of the key scientists in early work which led to the development of atomic energy. He has recently been serving as manager of the technical department of the Knolls Atomic Power Laboratory, now being operated by *G-E* for the Atomic Energy Commission.



HAROLD W. McCRAE, one of North America's foremost radar and electronic scientists, has been named manager of the Development Engineering Department at *Allen B. Du Mont Laboratories, Inc.*, Communication Products Division, Clifton, N. J. Formerly project head in charge of the *Du Mont* bright-screen radar program, Mr. McCrae will now have direct responsibility for engineering development of all electronic communication products made by the Division.



HERMAN J. SCHORLE has been appointed works manager of the new Manchester, N. H., plant of the *Insulinc Corporation of America*, manufacturer of electronic equipment. A graduate of the Massachusetts Institute of Technology with a degree in mechanical engineering, Mr. Schorle has had long experience in heavy industry. He was recently associated with the *Bendix Aviation Corporation* and with the *Worthington Corporation* in production positions.

Electronic Thermostat

(Continued from page 15)

ing a portion of the required power continuously and switching only the power needed to compensate for any load changes in the controlled process.

This thermostat has been used successfully to control a number of processes at NBS, and experience has shown that its sensitivity, stability, and flexibility make it valuable for many laboratory applications requiring precision temperature regulation. In a typical application, the thermostat has for many months held standard electric cells, immersed in an oil bath, to a controlled temperature of 28°C within $\pm 0.001^\circ\text{C}$. The temperature of a small heated-air oven is ordinarily difficult to control because of its low thermal inertia; using the NBS thermostat, the temperature in a small electrical furnace has been maintained to within $\pm 0.1^\circ\text{C}$ over a range from 250 to 450°C.

New Literature

(Continued from page 30)

corporated, 22 Cummington St., Boston 15, Mass. Complete magnetron, TR and ATR lines are covered, and a section entitled "Recent Trends in Microwave Radar Duplexing" should be of particular interest to design engineers in the microwave field.

THERMISTORS

What thermistors are, how they are applied, what functions they perform, and what benefits industry may derive from them are all explained in a new manual announced by the Carboly Department of *General Electric Company*, Detroit 32, Mich.

This 52-page publication, referred to as TH-13, includes much new information on thermistors, tests supplied by an independent laboratory, and characteristic curves. Illustrations are keyed so that a user can tell at a glance which style or type of thermistor is best adapted to his application.

TRANSISTOR CURVE TRACER

The transistor curve tracer manufactured by *Magnetic Amplifiers, Inc.*, is a completely automatic instrument capable of measuring all existing types of transistors. Measurements are made by displaying the whole family of curves on a cathode-ray tube and are accurate to 3% independent of scope drift or calibration. For a copy of a bulletin describing this unit, write to *Magnetic Amplifiers, Inc.*, 632 Tinton Ave., New York 55, N. Y.

MINIATURIZING YOUR EQUIPMENT?

Specify *SIMPLEST, MOST COMPACT*
AMPERITE
**THERMOSTATIC
DELAY RELAYS**

MOST ECONOMICAL, HERMETICALLY SEALED

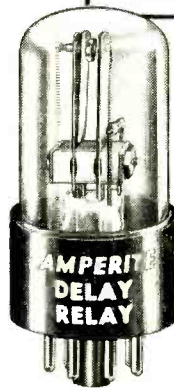

STANDARD



MINIATURE

Provide delays ranging from 2 to 120 seconds.

- Actuated by a heater, they operate on A.C., D.C., or Pulsating Current.

- *Hermetically sealed.* Not affected by altitude, moisture, or other climate changes.

- Circuits: *SPST only*—normally open or normally closed.

Amperite Thermostatic Delay Relays are compensated for ambient temperature changes from -55° to $+70^\circ\text{C}$. Heaters consume approximately 2 W. and may be operated continuously. The units are *most compact, rugged, explosion-proof, long-lived, and — inexpensive!*

TYPES: Standard Radio Octal, and 9-Pin Miniature.

PROBLEM? Send for Bulletin No. TR-81

BALLAST-REGULATORS

- **Amperite Regulators** are designed to keep the current in a circuit *automatically regulated* at a definite value (for example, 0.5 amp).
- For currents of 60 ma. to 5 amps. Operates on A.C., D.C., Pulsating Current.
- *Hermetically sealed, light, compact, and most inexpensive.*

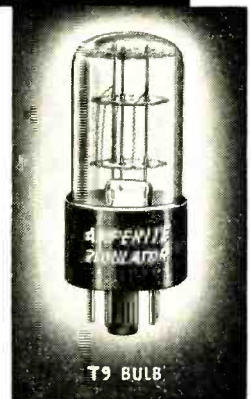
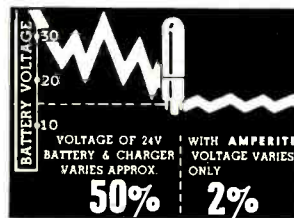
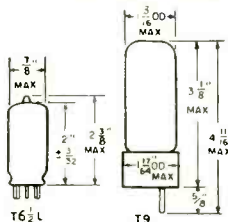

Maximum Wattage Dissipation: T6 1/2 L—5W. T9—10W.

Amperite Regulators are the simplest, most effective method for obtaining *automatic regulation* of current or voltage. *Hermetically sealed*, they are not affected by changes in altitude, ambient temperature (-55° to $+90^\circ\text{C}$), or humidity. Rugged; no moving parts; changed as easily as a radio tube.

Write for 4-page Technical Bulletin No. AB-51

AMPERITE CO. Inc., 561 Broadway, New York 12, N. Y.

In Canada: Atlas Radio Corp., Ltd., 560 King St. W., Toronto 2B

NEW TUBES

BEAM POWER TUBE

Capable of a 12-kw. power output at 900 mc., the RCA-6448 is the most powerful beam power tube so far developed for u.h.f. television broadcast-



ing. Announced by the Tube Division of *Radio Corporation of America*, Harrison, N. J., it is only $7\frac{3}{4}$ " in height and $1\frac{1}{8}$ " in diameter. In color or black-and-white TV service, it can also deliver a synchronizing-level power output of 15 kw. at 500 mc. As a c.w. amplifier in class C telegraphy, it can generate a useful power output of 14 kw. at 400 mc. or 11 kw. at 900 mc.

The ability of the RCA-6448 to produce such high power stems in large part from its unique design; it features a coaxial-electrode structure in which a centrally located plate is surrounded by a symmetrical array of unit electron-optical systems. This structural design makes possible close spacing and unusually accurate alignment of electrodes. Ducts are built in for water-cooling the various elements.

RUGGEDIZED TRIODE

A ruggedized water-cooled tube for heavy-duty r.f. industrial applications, the *Amperex* Type 6446 is a heavy wall triode capable of dissipating 20 kw. continuously. High heat storage capacity is provided by the $\frac{7}{16}$ "-thick anode for heavy intermittent duty, and the high dissipation reserve allows extreme mismatch of load-to-tube impedance. The 6446 uses only one-half the water flow required for Type 892 for equivalent anode dissipation.

In this tube, the conventional stem press construction has been replaced by a rugged glass stem which runs about 150° cooler, minimizing failure due to thermal shock. The projecting grid arm has been eliminated and replaced with a strong Kovar ring grid connection, and a strong conical internal grid support is incorporated in the design in-

stead of a three-legged riveted construction.

For additional information, write to the Engineering Department, *Amperex Electronic Corporation*, 230 Duffy Ave., Hicksville, L. I., N. Y.

PENTODE AMPLIFIER

Designed for use as a color demodulator synchronous detector in color TV circuits, the Type 6DB6 pentode amplifier is capable of being driven harder and giving larger outputs than tubes currently being used as color demodulators. Announced by the Electronic Tube Division of *Westinghouse Electric Corporation*, Box 2278, Pittsburgh 30, Pa., this tube may also be used as a sync separator with the accompanying advantages of a pentode-type tube, or it may be used as a mixer in black-and-white TV circuits.

The 6DB6 is a sharp-cutoff pentode amplifier of the 7-pin miniature type. Grids 1 and 3 are control grids for color demodulator use. The chromatic signal is applied to grid 1 and the output of the 3.58-mc. oscillator is applied to grid 3. When the tube is used as a color demodulator, output is linear for high levels of grid 3 drive.

COLOR TV TUBE

Chromatic Television Laboratories, Inc., an affiliate of *Paramount Pictures Corporation* currently engaged in developing and licensing the Lawrence color TV tube, has announced extensive



expansion plans for 1954. Manufacturing operations have begun on the grid—the color structure mounted at the face of the tube—at *Chromatic's* plant in Emeryville, Calif., and the goal for the year will be greatly in excess of 25,000 units.

The 21" rectangular all-glass model of the Lawrence color tube shown in the photograph is the first large-picture rectangular tube in the field. It is being produced by *Thomas Electronics Company*, Passaic, N. J., largest independent TV tube manufacturer in the industry and a *Chromatic* licensee.

HIGH POWER TRANSISTOR

Shown here is a high power transistor (along with the metal envelope in which it is mounted) currently under development at the Electronics Laboratory of *General Electric Company*, Syracuse, N. Y. No external cooling provisions



are required. The envelope is a plug-in unit.

G-E engineers have used such developmental transistors to build an experimental 20-watt linear audio amplifier which operates from dry cell batteries. Power transistors are expected to be available in production quantities within the next two years.

TETRODE TRANSISTORS

High-frequency grown junction tetrode transistors are now being offered to the electronics industry by the *Germanium Products Corporation*, a subsidiary of *Radio Development & Research Corporation*. Originally developed by the *Bell Telephone Laboratories*, these units make possible the commercial adaptation of the transistor to radio, television and communications equipment.

A data sheet which outlines the parameters of the transistors as tetrode oscillators and tetrode tuned amplifiers is available from the *Germanium Products Corporation*, 26 Cornelson Ave., Jersey City, N. J.

BONDED GERMANIUM DIODES

Raytheon's Receiving Tube Division has announced the first two types in a line of bonded germanium diodes utilizing new production techniques. Designed for magnetic computer and

similar applications where extremely low forward resistance and high reverse resistance characteristics are impor-

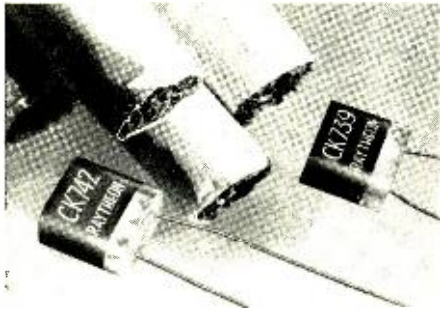

tant. Types CK739 and CK742 have forward resistances of 10 ohms or less at 1 volt and back resistances of several megohms at negative voltages as great as 125 volts.

The major difference between these two types is that the peak inverse voltage rating of the CK742 is 125 volts, double that of the CK739. Data may be obtained by writing to the Technical Information Service, Raytheon Manufacturing Company, 55 Chapel St., Newton 58, Mass.

"INDITRON"

The "Inditron" tube, developed in the Orange, N. J., Research Laboratory of National Union Radio Corporation, shows on a filament the digits or letters usually recorded on the mechanical dials

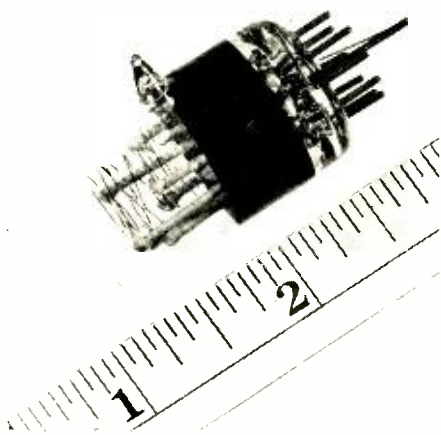

of tabulating machines. The number of digits or letters flashed from the recording device is determined by the number of Inditrons lined up in readable rows.

A glow indicator tube incorporating the latest applications of electronic control with the discharge principles used in common neon tubes, the Inditron can be built to any size within reason and can be read clearly several feet away in a miniature size. It is expected to have many uses in adding machines, electronic computers, scoring registers and other devices used to report tabulated information.

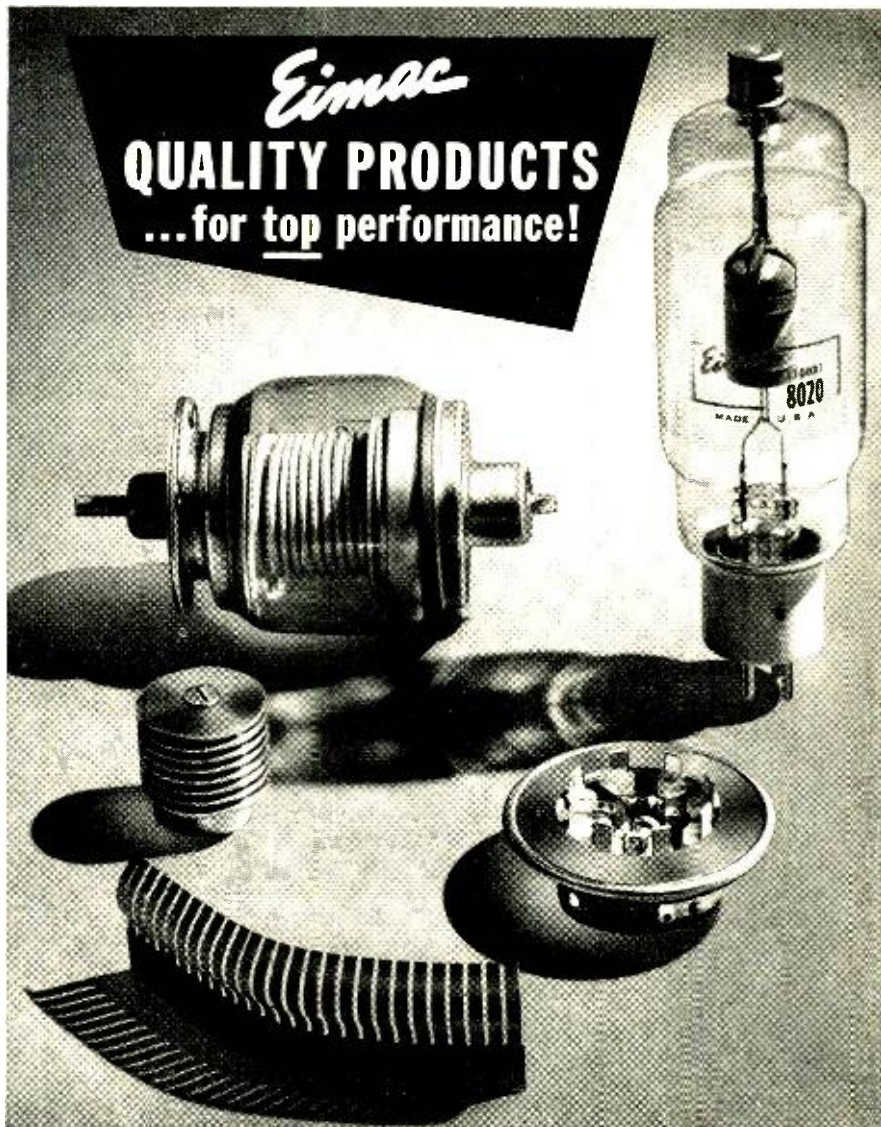

Preformed Contact Finger Stock is an ideal electrical weather stripping around doors of equipment cabinets as well as being excellent for use with VHF and UHF circuitry. Silver plated, it comes in three widths— $\frac{17}{32}$, $\frac{31}{32}$ and $1\frac{7}{16}$ inches.

Variable vacuum capacitors come in three models, are lightweight, compact, eliminate the effects of dust and atmospheric conditions and have low inductance. Also available are eight types of fixed vacuum capacitors.

Air-system sockets, designed for Eimac tube types 4-400 A, 4-1000A, 4X150A, and 4X150D, simplify cooling and assure adequate air-flow to various seals. The 4-400A socket can also be used with the 4-125A and 4-250A

radial-beam power tetrodes if desired.

HR heat dissipating connectors provide efficient heat transfer from the tube element and glass seal to the air while making electrical connections to plate and grid terminals. Precision machined from dural rod, HR connectors come in ten sizes to fit most of Eimac's internal anode tubes.

High Vacuum Rectifiers come in eight models, are instant heating, have radiation-cooled pyrovac* plates and can be operated in a variety of rectifying and voltage multiplying circuits. Also available are four types of mercury-vapor rectifiers.

* An Eimac trade name.

• For further information write our Application Engineering department

EITEL-McCULLOUGH, INC.
SAN BRUNO • CALIFORNIA
Export Agents: Frazer & Hansen, 301 Clay St., San Francisco, California



RADIO IN MATERIAL HANDLING

By **JEREMIAH COURTNEY**

Attorney at Law

Mobile radio communications can decrease operating costs in many operations such as material handling.

“ I WAS invited here particularly to discuss the Petition which the Committee on Manufacturers Radio Use recently filed with the FCC for additional frequencies in the so-called Citizens band. I think your group is to be congratulated on your awareness of the profound significance of the use of radio by manufacturing industries of the country. I have participated in the establishment of many new radio services, but I assure you that I regard my connection with the continuing effort of the manufacturing companies to establish a new radio service as far and away the most significant association I have had since devoting myself to mobile radio matters.

“There is one noncontroversial as-

Editor's Note: This article consists of excerpts from a talk given by Mr. Courtney before the Boston Chapter of the IRE Professional Group on Vehicular Communications at Massachusetts Institute of Technology, February 25, 1954.

pect of the Petition in which you may perhaps be interested because of its general applicability to the subject of our mutual interest. I think you will better appreciate what I have to say if I sketch in the background details. Herbert E. Markley of the *Timken Roller Bearing Company* and Victor G. Reis of the *Bethlehem Steel Company*, Chairman and Vice-Chairman, respectively,

of the Committee on Manufacturers Radio Use were sitting in my office dictating our Petition. We had reached the point where we wanted to explain briefly the function of mobile radio in manufacturing operations. How could we account for the extraordinary reception that radio is receiving by the manufacturing companies using it?

“We batted the subject around, went through five or six drafts, and finally came to what I regard as a universally acceptable explanation of the high importance of mobile radio to all users. Here is our definition of the function of mobile radio communications in manufacturing operations:

“The primary function of the managers of any enterprise is the projection of themselves to the greatest extent possible into every important part of the whole process. This has been true from the earliest times in man's productive activities. The one-man farm was operated ideally by the owner because he had direct control of the whole operation. When he engaged a hired hand to share the work and increase the productivity of his farm, he became a manager. As such, his problem was to get the work of the hired hand done as he would do it himself. The

SHAFT DISPLACEMENT INDICATOR

IN THE field of heavy rotating machinery, such as steam turbines and internal combustion engines, it is sometimes desirable to monitor the relative position of some moving member. Turbines, in particular, having certain types of load, are subject to rapid, unpredictable thrust bearing wear. Since the rotor and stator of a turbine are machined to close tolerances, excess longitudinal movement of the shaft presents the danger of interference of these parts and possible destruction of the machine. A shaft displacement indicator, which has been developed by L. A. Marzetta of the National Bureau of Standards at the

request of the Department of Defense, detects and measures accurately the shaft displacement in either direction. When the displacement exceeds a prescribed limit, the indicator actuates an alarm, thereby warning operating personnel of imminent machine failure. Since the instrument also gives a direct indication of the amount of bearing wear, a bearing may now be used for its full useful life.

The detecting element in this device is a mutual inductance micrometer developed by M. L. Greenough of the National Bureau of Standards. A transducer probe, consisting of two coaxial, co-

planar coils wound on a dielectric core about $\frac{1}{2}$ " in diameter, is mounted on the turbine frame near the shaft. When the primary coil is energized from a regulated r.f. source, a voltage is induced in the secondary coil. On the end of the turbine shaft is fastened a brass disc which forms part of the electrical system. Motion of the disc toward or away from the probe changes the mutual inductance between the two windings. Thus, the output voltage from the secondary is dependent on the spacing between the probe face and the brass disc. This voltage is indicated on a meter calibrated in thousandths of an inch and shows the shaft position relative to the main frame of the turbine. The probe assembly includes a graduated micrometer that provides for accurate adjustment of the spacing between the probe face and the disc.

Coupled to the micrometer probe is a five-tube exciter unit which contains a regulated carrier oscillator to furnish current for the probe transducer, the detector circuit, and the meter for indicating the shaft position. In a separate chassis are the power supplies and the alarm circuits.

Although the instrument's function is to measure displacement of a rotating shaft in a longitudinal direction, it can easily be adapted to measure motion in the radial direction. Moreover, it can be applied to indicate the relative positions of oscillating, reciprocating, or quasi-stationary members over a wide range of displacements, since the mutual inductance micrometer will measure lengths as small as 50 microinches or as large as several inches with an accuracy of 3%.

Shaft displacement indicator developed at NBS. Cabinet at left contains power supplies and alarm circuits. At center is the indicating unit and exciter unit, mounted in explosion-proof case for a special application. Transducer probe, in foreground, is the displacement-sensing element for this instrument. At right, exciter and indicator unit removed from case.

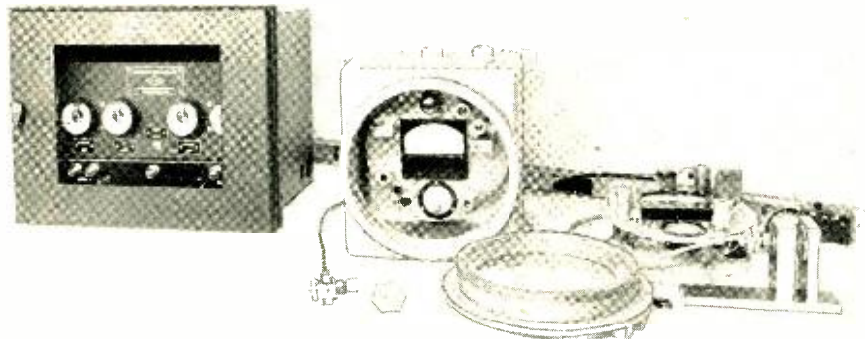

New circuit development obsoletes conventional UHF 2-Way Radio design

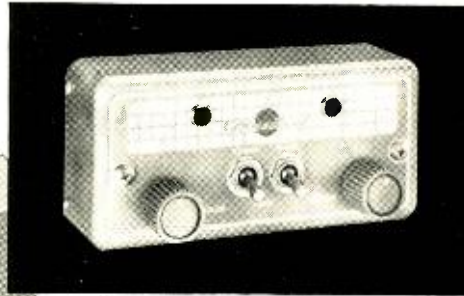
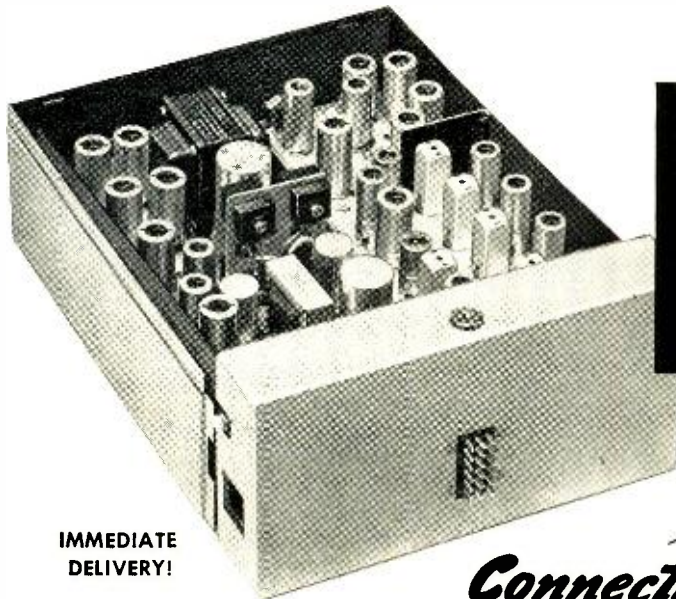

IMMEDIATE
DELIVERY!

Connecticut **FLEETWAY** FIRST FM 2-WAY RADIO

UNIQUE CONN-TENNA
DESIGN BEAMS STRONG
HORIZONTAL SIGNAL

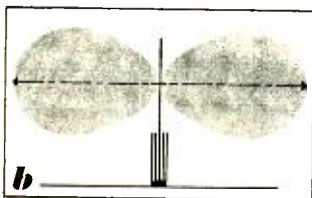
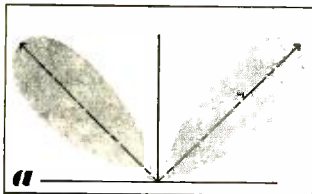

More evidence of FLEETWAY's radical design is found in its new Conn-tenna. Sketch *A* shows how conventional monopole antenna dissipates much of its signal at 45° upward angle. Sketch *B* shows how multipole Conn-tenna concentrates radiation along a horizontal plane, transmitting a stronger signal with lower power requirement.

HIGHER OVERTONE • The patented Lister circuit uses a starting frequency of 75 Mc instead of the usual 6 Mc. Low 6-time frequency multiplication required to reach 450 Mc contrasts with 24-times or more in other types of equipment.

GREATER STABILITY • Direct circuitry and fewer components permit better control of signal output, greatly minimize drift and spurious radiation. Result is greater stability requiring minimum maintenance, producing clearest signal ever attained in mobile radio.

'FM' CLARITY MINUS NOISE • True frequency modulation — for the first time in mobile radio — produces noise-free, natural tone quality, and eliminates distortion so common in conventional equipment. *This is true FM, not commonly used phase modulation (PM).*

LOWER OPERATING COST • Simplified FLEETWAY circuitry requires fewer tubes and parts — uses standard, lower cost crystals and tubes, needs less servicing.

NEW 450-470 Mc BAND OPENS 2-WAY RADIO TO EVERY CITIZEN AND COMPANY

• Even if you have not been able to obtain a license for 2-way radio for yourself or your business, the chances are you can now get an immediate assignment in the recently opened 450-460 commercial fleet band or in the 460-470 citizens' band. These new bands offer easy licensing requirements for anyone who does not qualify in one of the older channels. You can now enjoy the advantages of FLEETWAY mobile radio for business or private use.

See your local FLEETWAY dealer or write for "Technical Comparison" booklet containing parts and performance comparison of leading mobile radio equipment.

Connecticut

CONNECTICUT TELEPHONE & ELECTRIC CORP. 100 BRITANNIA ST. MERIDEN, CONN.



PHOTODIODES



PHOTO CONDUCTORS

Offer These Important Features

- SMALL POWER CONSUMPTION
 - MINIMUM POWER LOSS
- OPERATE AT EXCEPTIONALLY LOW VOLTAGES
 - LOW NOISE LEVEL
- GOOD OPTICAL SENSITIVITY
 - MICRO-SIZE
- HIGH OPTICAL RESOLVING POWER
 - SIMPLE ASSOCIATED CIRCUITRY
- RUGGED — LONG LIFE — LOW COST

Hundreds of Applications!

In Photoelectric Controls — Optical Tape Read Out — Punch Card Optical Read Out — Telegraphic Optical Read Out — Infra-red Burglar Alarms — Liquid Level Controls — Automatic Automobile Headlight Dimmers — Moving Picture Variable Density Sound Read Out — Automatic Brilliance Controls on TV Receivers — and many others.

Write for free report — *Photodiodes and Phototransistors* — describing mechanics of operation, circuits, photovoltaic cells, etc.

For data sheets and complete information on CLEVITE transistors, diodes and transistor test set, write Dept. R.



TRANSISTOR PRODUCTS, INC.

SNOW AND UNION STREETS, BOSTON 35, MASSACHUSETTS
AN OPERATING UNIT OF
CLEVITE CORPORATION

solution for him was easy: oral instructions, which could be altered quickly during the day as required. Now a manager often is responsible for instructing and supervising hundreds of employees, but the basic problem in directing a working force remains with him—he must still try to get the work done essentially as he would do it himself or as he would wish it done, even though it is physically impossible for him to oversee all parts of the operation directly.

“The difficulties of the problem are intensified in modern industry when operational areas are large and scattered and production procedures are complex and interdependent. Rapid communication is an important element in overcoming the difficulties. Through the years, many well-known and efficient transmitting methods have been developed, and industry has made full use of the telegraph and the telephone and other fixed wire-line facilities. Radio, however, is used when wire lines cannot be used at all, as in the operation of mobile vehicles, from which it is obviously impossible to trail wires; it is also used in certain kinds of operations where wire lines would be cumbersome or hazardous or uneconomical, and in the activities of mobile working crews in locations where only a portable communications system is feasible or desirable. In all these cases, radio communications permit more effective disposition of vehicles and personnel, which in turn results in substantial conservation of machine-hours, man-hours and vehicle-hours, or—in short—lower costs of production.”

“I firmly believe that the use of radio in manufacturing operations—and I don’t mean for general transportation purposes, but as it is actually integrated into the production line—holds out almost limitless possibilities, given sufficient frequencies.

“For the doubting Thomases, if any there be, some chapter and verse citation may be in order. In any large company, one department will frequently operate independently of the other. Each department knows what its material handling unit requirements are, but they have normally been calculated in terms of urgent requirements. Without radio, the only way a particular department could be sure a handling unit was available when needed was to have plenty of units assigned to its independent use.

“To describe this system of operations is to condemn it. But there was no satisfactory solution before radio inasmuch as any department with permanently assigned units would be opposed to letting them go—whether or not they were idle most of the time—because it was difficult to locate the units, once

beyond their control, for later lifts. The result would be wasted equipment and manpower.

“How about the handling requirements of departments not having assigned units? Were their shipping problems well handled without radio? To describe the method employed there is again to condemn it. Shippers in departments not having assigned units might attempt to lure a roving unit—tractor, truck, fork lift or straddle—by hanging colored placards in the vicinity of the shipping area of the department. The color of the placard indicated the type of handling unit required, and the success of the system depended upon the initiative of the driver in seeing the job-call—something like trying to attract an experienced waiter who may or may not want to serve you at the moment.

“Of course, shippers in extremis could hail the passing unit or otherwise commandeer it—while someone else waited. Or the shipper might call the Transportation Department, where the uncontrolled job assignments accepted by the roving units usually meant slow service, or possibly the arrival of a unit as a commandeered unit pulled away. I could go on, but I think the picture of catch-as-catch-can material handling to which the radioless manufacturer is condemned is quite clear.

“The inauguration of a two-way radio-central dispatch system, however, puts control of all material-handling units in the dispatcher, and invariably results in a vast improvement in handling service. Some units may continue to be assigned to departments having considerable traffic, but fewer than before radio. The dispatcher, furthermore, retains control and may pull idle units for use elsewhere, or may for urgent lifts overrule the department shipper and temporarily reassign a unit.

“Requests for service (other than for assigned units) are all cleared by the dispatcher, who knows the location of all handling equipment in the yard. At the time of service request, the dispatcher can determine the relative priority of each call, and assign the units accordingly. He also tries to find “return” trips for the equipment, so that deadhead travel time is a minimum.

“Urgent requests are rapidly filled, as the dispatcher can readily locate the proper unit, and has instant contact by radio.

“The success of the radio-controlled materials-handling system turns in large degree upon the ability of the dispatcher. He must have a thorough knowledge of the yard layout, the facilities at each shipping point, the capabilities and limitation of the equipment, and the location of all equipment at all times. He must be familiar with the

types of materials handled and with the recommended shipping methods. A calm disposition and ability to sense the true priority of service requests also are great assets.

"Radio offering the only assurance so far developed that the right amount of material will be available at the right place at the right time, can anyone question the expansion that will occur in manufacturing company radio use as the ingenuity of our brilliant manufacturing executives—in which our country above all others abounds—is directed to the improvement of material-handling practices?"

"Again for the doubting Thomases, if any there be, the economic and national importance of what I am about to say cannot be overemphasized. It is this. In almost all types of manufacturing operations, there is a considerable amount of indirect costs. One of the major elements of those indirect costs is material handling. Other costs of manufacture having become largely standardized, we have reached the stage today where in many cases the only opportunity one manufacturer will have to improve the price of his competitor will be through improved material-handling practices.

"There is one final thought I would like to leave with you. It really sums up just about everything I have been talking about. Industrial management is now catching up with the rest of the world in the matter of communication by radio. For many, many years, ships at sea, airplanes and police departments have been distributing important information and coordinating their activities by means of radio communications. Industry in many areas has meanwhile been relying on the visual signs, footwork or oral communications, or has been without any sort of communications. The ultimate results of the search by manufacturing companies for the application of radio communications in all feasible areas will be the establishment of a phenomenal number of radio systems. The research studies and experimental operations

ZOPHAR

WAXES COMPOUNDS

Zophar waxes, resins and compounds to impregnate, dip, seal, embed, or pot, electronic and electrical equipment or components of all types; radio, television, etc.

Cold flows from 100°F. to 285°F.

Special waxes non-cracking at —76°F.

Compounds meeting Government specifications, plain or fungus resistant.

Let us help you with your engineering problems.



ZOPHAR MILLS, INC.
112-130 26th Street,
Brooklyn 32, N. Y.



Specifically Designed For
Rugged Mobile Communications Service

DEPENDABLE and Trouble-Free VIBRATORS



Select your replacement vibrators wisely... and you, too, will choose Radiart! Laboratory tests and customer reports prove that Radiart Vibrators give LONGER LIFE and trouble-free performance BECAUSE THEY ARE BUILT TO WITHSTAND RUGGED SERVICE! These extra hours of dependable performance is one of the factors that has made Radiart the leader. Superior engineering and design have made them THE STANDARD OF COMPARISON.

At all good radio parts jobbers. Ask for the new Form F781 listing the latest replacement recommendations.



IT'S RIGHT WHEN IT'S RADIART

THE RADIART CORPORATION
CLEVELAND 13, OHIO



- ROTORS
- VIBRATORS
- TV ANTENNAS
- AUTO AERIALS
- POWER SUPPLIES

in this field can best be progressed by you people in the audience. You have an unlimited scope for your imagination and inventive abilities, and if the job is properly done, you will leave a permanent, shining mark on the development of radio communication systems in industry."

AM-FM Monitor

(Continued from page 20)

dependent on the product of R_2 and C_1 . The purpose of control R_3 is to adjust for the correct plate current flow to actuate the relay properly.

The unit begins its cycle when switch S_1 is closed, completing the circuit to battery B_1 . Current flows through the tube and relay winding due to the condition of zero bias on the grid. The relay pulls in, placing resistance R_1 and battery B_2 across capacitor C_1 . This action gradually removes the zero bias and begins applying a negative bias to the grid, increasing as the capacitor charges. Current flow through the tube and relay winding is reduced by the increasing negative voltage, the relay dropping out to normal position when the current decreases sufficiently. The d.p.d.t. relay contacts are so arranged that when the relay opens B_2 and R_1

are removed, and resistor R_2 is connected across the capacitor. The capacitor then begins discharging through R_2 , which results in a decreasing negative bias voltage on the tube grid. When the bias drops sufficiently, enough plate current flows to energize the relay, and the periodic cycle begins again. The other set of d.p.d.t. relay contacts simultaneously switches the program channels to the monitor.

Time intervals during which the relay remains open and closed can be identical or of widely different duration, the resulting combination depending on the ohmic values of R_1 and R_2 . It may be desirable in the case of AM-FM monitoring, where the FM transmissions are of secondary importance, to provide a short time duration for FM checking with a considerably longer period for AM monitoring. These time intervals, together with the FCC required half-hourly meter readings, would seem to be adequate for monitoring during normal operation.

The second problem presented near the beginning of this article, that of providing some indication of failure of the program transmission channel not being aurally monitored at a particular time, can be resolved as shown by the circuit diagram of Fig. 2. Another 12AT7 tube is used, the twin triode sections being connected with a relay in each plate circuit. A negative biasing voltage obtained from the tuner or radio receiver used to pick up the AM signal is fed to the grid of one section of the 12AT7. This bias is of such value that insufficient plate current flows to operate relay RL_1 . Likewise, a negative bias voltage is taken from the FM tuner or receiver and applied to the grid of the other section of the tube, thus preventing operation of relay RL_2 . The contacts of these two relays are in series with one leg of the speaker connections; and when the relays are in a de-energized state, the speaker circuit is unbroken. Breakdown of either AM or FM facilities will remove the negative bias from the grid of the corresponding section of the twin triode, and current will flow in this section. Relay RL_1 or RL_2 will close, depending upon which program channel has failed, thereby interrupting the speaker circuit and cutting off the loudspeaker. Switches S_1 and S_2 are across the relay contacts. When speaker cutoff occurs, operating either of the switches will restore the circuit and give evidence of which transmission channel has failed. It can be seen that speaker cutoff will occur with failure regardless of which channel is being aurally monitored at the time.

In the AM section, negative bias voltage can be obtained from the a.v.c. circuit of the receiver. The FM section

may be biased with a negative voltage taken from the grid of a limiter stage. Voltage developed across the grid-leak resistor at this point, as in the case of the a.v.c. of the AM receiver, is proportional to the strength of the r.f. signal being received. Resistors R_1 through R_3 may vary in value with different receivers or tuners.

No special constructional precautions are required for this device, any arrangement to suit individual conditions being satisfactory. The unit can be built into a small metal cabinet. All component parts may be mounted on the front cover and shelf of the cabinet, including terminal strips for external connections. Connections to the unit can be made through grommet-fitted holes in one side of the cabinet, thus providing for either table use or rack and panel mounting. For rack mounting, the cabinet may be fitted at the rear with small brackets for fastening to a standard rack panel.

In the schematic diagram of Fig. 1, batteries are shown for simplicity in analyzing the circuit. Conventional power supplies of suitable voltages may be used, or power can be obtained from other available apparatus. A supply employing selenium rectifiers is shown in Fig. 3. If different tube types and less sensitive relays are used, a voltage doubling circuit with selenium rectifiers might be convenient.

★ ★ ★ ★ You Can't Fall IT'S A LIFE SAVER



IT LOCKS—IT HOLDS
Prevents death and injuries
from falling.

SAFETY DEVICE FOR LADDERS

Easy and inexpensive to install: Clamps to rung, peg, pole or frame. No welding or cutting. Simple to operate: No upkeep. Requires no attention from climber. Anyone can use it. Safety Specifications: High safety factor. Will not rust or corrode. Write for folder.

Safety Tower Ladder Co.

1024 Burbank Blvd. P.O. Box 1052
BURBANK, CALIFORNIA

Also Manufacturers: Safety Lifeline Lock



Member

National Safety Council

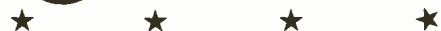

CALENDAR of Coming Events

MAY 24-26—National Telemetering Conference, Hotel Morrison, Chicago, Ill.

MAY 25-27—NARTB Broadcast Engineering Conference, Palmer House, Chicago, Ill.

JUNE 9-11—Eighth Annual Convention of the American Society for Quality Control, St. Louis, Mo. U. C. Gramsch, Registrar, P. O. Box 4436, Wade Station, St. Louis 15, Mo.

JUNE 17-18—Forestry Conservation Communication Association Fifth Annual Conference, Hotel Commodore, New York, N. Y. Program Chairman: Max Guiberson, Route 7, Box 392, Olympia, Wash.

JUNE 21-25—AIEE Summer General and Pacific General Meeting, Hotel Biltmore, Los Angeles, Calif.

JUNE 23-26—Acoustical Society of America, 47th Meeting, Hotel Statler, New York, N. Y.

JULY 8-12—Convention on Industrial Electronics, Oxford, England, sponsored by The British Institution of Radio Engineers, 9 Bedford Square, London W.C. 1, England.

AUGUST 25-27—WESCON (Western Electronic Show and Convention), Pan-Pacific Auditorium and Ambassador Hotel, Los Angeles, Calif.

A BIG SURPRISE IN A SMALL PACKAGE

*the
new*

AMPEX

600



WEIGHS ONLY 26 LBS.

The most portable truly high fidelity tape recorder ever built.

**PERFORMS LIKE
A TRUE AMPEX**

Frequency response is 30 to 15,000 cycles at 7½ in/sec; signal-to-noise ratio over 55 db; and every machine is tested to meet or exceed specifications.

**SERVES ALL BROAD-
CASTING NEEDS**

For recording, editing, dubbing and broadcasting, it's a full time troublefree machine. Major components have been "life tested" for an equivalent of 10 years' normal use.

**COSTS LESS THAN
ANY AMPEX BEFORE**

It's simpler and lighter, but it's all Ampex — and still the best.

AMPEX

CORPORATION

*For full
description and
specifications,
write today
to Dept. T-1695.*

934 CHARTER STREET • REDWOOD CITY, CALIFORNIA

Distributors in principal cities (listed in the "yellow pages" under "Recording Equipment"); distributed in Canada by the Canadian General Electric Company

New Products

(Continued from page 25)

the multiplexer will permit instantaneous shifting of the camera pickup among these sources.

DOUBLE PULSE GENERATOR

Now being manufactured by *Berkeley Scientific*, division of *Beckman Instruments, Inc.*, Richmond, Calif., the



Model 4904 double pulse generator provides a source of "single" or "paired" pulses for laboratory testing of electronic pulse circuits such as counters, gates, switches, and amplifiers.

Model 4904 consists of two basic pulse-forming circuits which are triggered at a variable repetition rate by either an internal or an external frequency source, or by a manually operated switch. A time delay circuit supplies the variable separation between the first and second output pulses. The output of each pulse-forming circuit is obtained from a power amplifier which gives large output with small base-line variations.

VOLTAGE METER

Convenience of operation, high sensitivity, stability and light weight are features of the Type 213 h.f. phase and vector voltage meter. Announced by *Advance Electronics Co., Inc.*, P. O. Box 394, Passaic, N. J., it is based on a differential rectifier circuit developed by the *Advance* engineering staff,

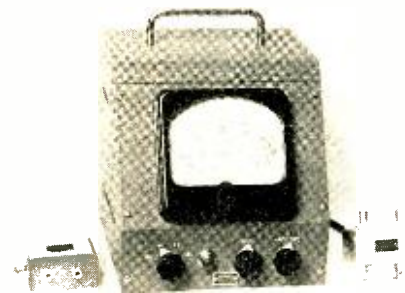

and can be used in the measurement of antenna systems, filters, amplifiers, and other high frequency transmission networks.

Frequency range of the Type 213 is 10 kc. to 300 mc. with a jack-input probe, and 100 kc. to 1000 mc. with

a coaxial probe, both of which are supplied with the instrument. Input impedance is 2.5 μ fd. shunted by 100,000 ohms with the jack-input probe; the coaxial input probe is normally designed for 50 ohms characteristic impedance. The voltage range is 0.6, 60 and 6 volts full scale, and accuracy is $\pm 5\%$ nominal.

RELAY AMPLIFIER

The *Goldak Company* has announced the availability of a Model 200 relay amplifier for use in aircraft, missiles and any installation where heavy-duty vibration-resistant relays must give positive triggering from low input currents. Model 200 provides 28 volts at 400 to 600 ma. d.c. for driving stepping switches or 250 ma. continuously for the operation of 50-ampere aircraft relays.

The input signal can be either positive or negative or a.c. (approximately 60 to 5000 cps); the fact that a.c. can be used as a triggering voltage is con-

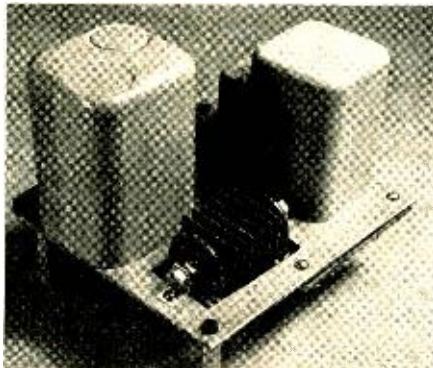

venient in that conventional audio circuitry may be utilized. Input operating current is less than 1 ma. For complete specifications, write to *The Goldak Company*, 1544 W. Glenoaks Blvd., Glendale 1, Calif.

DIELECTRICS

Glennite nonlinear dielectrics are available in thin sheets from .002" to .025" thickness or as finished units complete with electrodes, leads and protective coatings. Narrow loop materials have low losses and are suitable for high frequency use; square loop bodies have high remanent polarization necessary for memory work.

Typical applications for these materials are in dielectric amplifiers, memory devices, modulation, voltage tuning, frequency doubling, sweep circuits and variable filters. For further information, write to *Glenco Corporation*, Metuchen, N. J.

PULSE TRANSFORMER PACKAGE

Pulse transformer sample package SP-1 is being offered by *Berkshire Lab-*

oratories, 504 Beaver Pond Rd., Lincoln, Mass., so that engineers and technicians may have three types of pulse transformers immediately available when

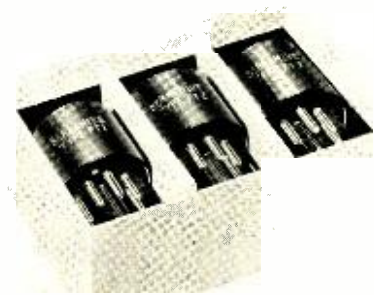

needed for experimental circuits, development models or prototypes. The three types included in this package—PT-1, PT-2 and PT-3—differ chiefly in the amount and kind of material used in the cores. All of octal tube base plug-in construction with cores of high quality magnetic material, wound, and uncut, they may be used for blocking oscillators, coupling, impedance matching, etc.

"DIGITESTER"

Resistance, voltage and current are measured in decimal numbers with the new "Digitester" developed by *Telecomputing Corporation*, 133 E. Santa Anita Ave., Burbank, Calif. Serving as a combination digital volt-ohm-milliamperemeter, the Model 48A has an accuracy of 0.1% and .8-second speed.

Wide measuring ranges are featured in this unit: up to 10 megohms can be measured in seven ranges, 1000 volts in six ranges, or 1 ampere in six ranges. Maximum accuracies (lowest scales) are: $\pm .01$ ohms; $\pm .00001$ volts; $\pm .01$ microamperes. Operation does not in-

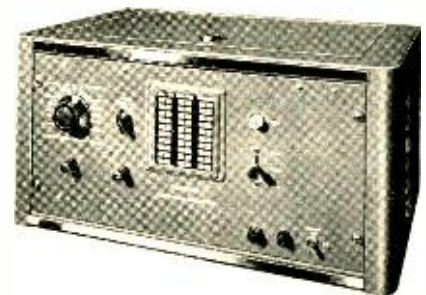

volve any manual adjusting or balancing—pressing a button gives decimal readout—and no accessories or external references are necessary.

DISTORTION METER

Features of the new *Freed* Model 1410 distortion meter include a frequency range of 20 kc. to 1 mc. in ten overlapping ranges, and a distortion range from 0.1% to 30%. The input level range allows signal levels from .2 to 1000 volts to be measured directly;

accuracy of 0.1% can be obtained at signal levels as low as .2 volts.

An easy-to-read 4" meter is used as a distortion indicator and monitor, the meter being protected against overload. Residual signal is measured by a high gain v.t.v.m. with flat response up to 3 mc. Self-contained and a.c. operated, the Model 1410 has a low impedance distortionless preamplifier with monitoring circuit, and a null *T* network assures complete attenuation of fundamental. For further information, write to *Freed Transformer Company, Inc.*, 1715 Weirfield St., Brooklyn 27, N. Y.

COMPARISON BRIDGE

Accuracy of a laboratory bridge is combined with the speed required for production testing in the Type 1604-B comparison bridge which has been announced by *General Radio Company*, 275 Massachusetts Ave., Cambridge 39, Mass. Providing test frequencies of 400, 1000 and 5000 cycles, it is adaptable to



either direct measurement or high speed sorting.

Because this bridge can check all types of components having impedances between 2 ohms and 20 megohms, with a basic accuracy of 0.1%, its applications are wide and varied. Two impedance deviation ranges are available by means of a panel switch which selects a $\pm 5\%$ or a $\pm 20\%$ range. The dissipation-factor difference range is proportional to frequency and is ± 0.006 at 400 cycles and ± 0.075 at 5000 cycles.

D.C. AMPLIFIER

The Series 80 d.c. amplifier announced by the *Fielden Instrument Division of Robertshaw-Fulton Controls Company* converts low level d.c. microampere or millivolt inputs to a high level d.c. current output. Simple in design, it is being offered as a single input or triple range unit. Ranges extend from 5 μv . and 20 μa . full scale, and the output is 5 ma. full scale.

Incorporating a high gain feedback loop, the Series 80 amplifier has excep-

better all around...

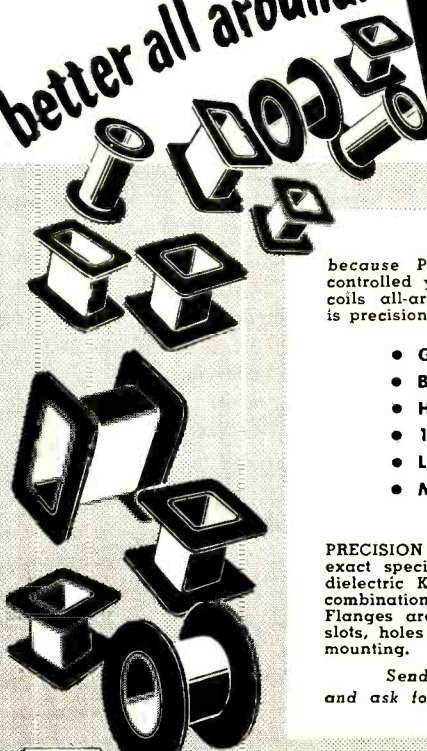

Precision COIL BOBBINS

because PRECISION Coil Bobbins are quality controlled you can be sure they'll improve your coils all-around. Every PRECISION Coil Bobbin is precision-engineered to give you:

- Greater Insulation
- Better Heat Dissipation
- Higher Moisture Resistance
- 15 to 20% Greater Strength
- Lighter Weight
- More Winding Space

All at lower unit cost!

PRECISION Coil Bobbins can be designed to your exact specifications . . . any size or shape in dielectric Kraft or fish paper, cellulose acetate, combination or phenol impregnated materials. Flanges are supplied plain or fitted with leads, slots, holes flat, recessed or embossed to fit any mounting.

Send specifications for free sample and ask for new Arbor list of over 2000 sizes.



PRECISION PAPER TUBE CO.

2063 W. Charleston St.

Chicago 47, Ill.

Plant No. 2, 79 Chapel St., Hartford, Conn.

Also Mfrs. of PRECISION Paper Tubes

NOW—COVERAGE TO 500 MC!

Save time . . . space . . . and money . . . maintain frequency and FM swing on all your mobile-radio channels with just these two small, rugged meters!



**LAMPKIN 105-B
MICROMETER FREQUENCY METER**

Uses one crystal to measure all transmitters from 0.1 to 175 mc., and crystal-controlled transmitters to 500 mc. Gives readings of per cent error from assigned frequencies. Acts as precision CW signal generator for receiver final alignment. Width less than 13" . . . weight less than 14 lbs. \$220.00.

MEET
FCC
SPECS



**LAMPKIN 205-A
FM MODULATION METER**

Direct indication of peak voice deviation, 0-25 kc positive or negative. Tunable 25-500 mc. in one band. Doubles as relative field-strength meter. Built-in speaker. Jack for oscilloscope. Width 12 1/4", weight 14 lbs. Price \$240.00.

MAIL COUPON TODAY!

LAMPKIN LABORATORIES, INC.
PRODUCTION DIVISION
BRADENTON, FLORIDA

Without obligation, please send more data on Lampkin meters.

Name _____
Street _____
City _____ State _____

**"NO RADIO SYSTEM IS BETTER
THAN ITS MAINTENANCE"**

ROHN
"Superior Design"
COMMUNICATION TOWERS

Proved in Construction, Design, and Operation.
Truly the finest tower of its kind. Made of heavy-duty tubular steel, electric welded throughout. In 10-ft. sections for easy erection, 14-in. triangular design. Can be used non-guyed to 60-ft.—guyed up to 150-ft.

Get the full facts today!
Call your Rohn representative or write, phone or wire:
"Pioneer designers and manufacturers of all type towers."

ROHN MANUFACTURING CO.
DEPT. CE • 116 LIMESTONE, BELLEVUE
PEORIA, ILLINOIS • PH. 4-9184

PLANS
into PLASTICS

PRECISION MACHINING OF ALL THE PLASTICS

including
POLYSTYRENE • COPOLYMER 1422
BUTYRATE • NYLON • TEFLON • KEL-F

PLASTIC FABRICATING

Printloid is equipped for the complete production of a wide variety of consumer and industrial items in any quantity. We work with any plastic material in sheets, rods and tubes. Die-cutting, deep drawing, stamping, forming, finishing, and assembling in our own plant.

PRINTED CIRCUITS

Fully equipped for the production of printed circuits including photo etching and silk screen. Vacuum forming of plastics to your specification.

Ask for brochure illustrating various plastic products fabricated to specification by Printloid.



tional long- and short-term stability characteristics. It is suitable for many laboratory applications involving the measurement or recording of low level d.c. signals, and for industrial use as



well—particularly as a thermocouple amplifier. Complete information may be obtained from *Fielden Instrument Division, Robertshaw-Fulton Controls Company*, 2920 N. Fourth St., Philadelphia 33, Pa.

VIBRATION ANALYZER

While operating under any simulated condition of load or speed, the *IRD Model 553* vibration analyzer permits selective readings of steady state vibration phenomena from as many as six points on a device or machine under test. Originally used to study vibration in jet engines, it enables checks of vibration phenomena to be made at full power.

As many as six *IRD* seismically mounted inductive pickups can be fastened at the points of stress to be

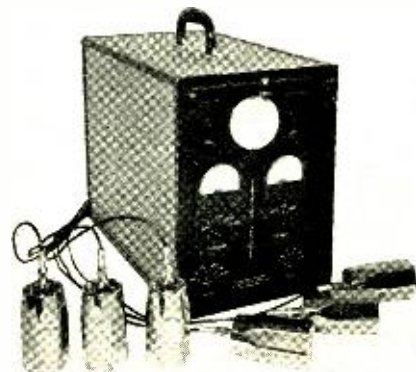

analyzed, and readings are made by means of a six-position input selector switch. Amplitude of vibration—peak-to-peak displacement—may be read directly in any of four selective ranges, and frequency of vibration may be read directly in any of three ranges.

A four-page folder giving detailed specifications is available on request from *International Research and Development Corporation*, 168 Hosack St., Columbus, Ohio.

Professional Directory

GEORGE P. ADAIR
Engineering Co.

Consulting Engineers

Radio, Television, Communications,
Electronics

1610 Eye St., N.W. EXecutive 3-1230
Washington 6, D. C.

Paul W. Klipsch
Professional Engineer
Acoustic development
and consulting

Klipsch and Associates
building the authentic
KLIPSCHORN
world's finest sound reproducer

Hope, Arkansas Tel. Hope PRospect 7-3395

FRANK H. McINTOSH

Consulting Radio Engineer

1216 Wyatt Bldg., Washington 5, D. C.

MEtropolitan 8-4477
Member AFCEE

MEASUREMENTS CORPORATION



Research & Manufacturing Engineers

Harry W. Heuck John M. Van Beuren M. A. Hannell
Specialists in the Design and
Development of Electronic Test Instruments
BOONTON, N. J.

GABRIEL ELECTRONICS DIVISION



Formerly Workshop Assoc. Div.
THE GABRIEL COMPANY

Specialists in High-Frequency Antennas

Endicott St. Norwood, Mass.
NORWOOD 7-3800

RATES FOR PROFESSIONAL CARDS IN THIS DIRECTORY

Single insertions—\$24.00
6 times—\$21.00 per insertion
12 times—\$18.00 per insertion

Tube Reliability

(Continued from page 14)

"Crash A" program is attempting to improve the quality and life of twelve types of tubes for many military aircraft requirements. Through the Panel on Electron Tubes, the Services have coordinated a means of returning failed tubes from the field; this is accomplished through a contract with ARINC. In operation, ARINC collects failed tubes at various Air Force, Army and Navy installations. A portion of these tubes is forwarded to Cornell University for analysis and the remainder shipped to the manufacturer of origin. ARINC places improved types of tubes into critical equipment sockets, and then keeps a close watch on their operation. The Cornell Analysis Laboratory was established to provide a means of determining the nature of tube failures across broad lines of tubes. This work will probably suggest research programs leading to further improvements in tube reliability.

Necessary as the above programs are, it must be realized that they are essentially short-range in scope and in answer to an immediate need. It is therefore encouraging to note that a long-range program for improving tube reliability also exists and is receiving energetic Service support. This program, too, is being coordinated through the Panel on Electron Tubes and consists of the following activities:

1. Oxide cathode investigations are sponsored at various industrial and university laboratories. The results of the research will be felt in improved and long-lived cathodes.
2. Filamentary alloys are being investigated, and new materials have been developed which possess superior high temperature and mechanical properties as well as improved thermionic emission.
3. An investigation of hot bend strength of cathodes should develop cathode base materials that will minimize the effect of heavy shocks on the cathode.
4. A project on accelerated life tests is in progress to investigate the causes of failure during life. This may lead to a series of tests that can predict, in a statistical sense, the quality of a lot of tubes in a much shorter period of time than is necessary in conventional testing.
5. The design features of filamentary and cathode-type tubes are being studied with the object of reducing microphonism.
6. Production engineering of subminiature tubes originally developed for the Navy and Air Force is in progress. These tubes are ruggedized and are capable of operation under severe environmental conditions with

high reliability and long life.

7. A Tri-Service contract of large magnitude has been let in order to develop procedures for the automatic production of tubes. The use of ceramic tubes is also being investigated in these studies. Tubes produced in this manner should have greater uniformity and increased reliability under severely adverse environmental conditions.

A great deal of progress has been made, but much remains to be done. Consequently, the Joint Electron Tube Engineering Council (JETEC) of the National Electrical Manufacturers Association and the Radio-Electronics-Television Manufacturers Association has undertaken a review of the reliable tube situation. Although several manufacturers have been working for some time on various lines of "reliable" or "premium" tubes for military and commercial applications, it has appeared essential that a more unified method of approach be developed. It is hoped that such an approach can be realized through more complete industry participation. The first step in the JETEC approach to the tube reliability problem is the development of objective and realistic tube ratings based upon the application in mind. The next step is the development of adequate specifications, both product and acceptance, by which the quality of the product may be determined and maintained; these adequate specifications must be based on actual tests and on life tests performed under conditions approximating as closely as possible the range of application requirements.

After adequate specifications have been developed for defining and evaluating, they should be supplemented and extended into production and assembly processes as well as into the realm of incoming parts and materials. These systematic manufacturing processes should be established and maintained in such a manner that a maximum of information becomes available as supporting evidence of tube quality, because then acceptance specifications may be written with a minimum of complexity and in such a manner that when considered together with systematic product controls and realistic tube ratings they will give a very complete picture of tube quality.

Proper Application

Proper application of tubes can minimize an important source of failure. For example, in an application involving the use of six sockets for tube type 5R4GY, it was found that the parallel connection of several tubes is not beneficial to the operation of a rectifier, especially if no precaution is taken to balance the load among the various

...designed for Kinescope Recording...and also shoots regular Live Action 16 mm Sound-On-Film Talking Pictures with no Camera modification! The "Super 1200" Camera with "TV-T" Shutter (Pat. Appl'd. for 1949) can Kinescope Record a 30 minute continuous show using 1200 foot film magazines. Write today for information and prices.

USE AURICON "TV-T" KINESCOPES FOR:

- ★ DELAYED RE-BROADCASTING
- ★ SPONSOR PRESENTATIONS
- ★ COMPETITION CHECKS
- ★ PILOT KINESCOPES
- ★ SHOW-CASE FILMS
- ★ "HOT KINES"
- ★ AIR CHECKS

Auricon 16 mm Sound-On-Film Cameras are sold with a 30-day money-back guarantee. You must be satisfied!

Auricon 50 ft. Kinescope "TV-T" Demonstration Films are available on loan to TV Stations and Film Producers. Please request on your letterhead.



BERNDT-BACH, INC.

7349 Beverly Blvd., Los Angeles 36, Calif.

MANUFACTURERS OF SOUND-ON-FILM
RECORDING EQUIPMENT SINCE 1931

tubes or to prevent overloading of the other tubes when one tube in the circuit fails to take its share.

The Panel on Electron Tubes, by Joint Service Contract, makes available a team of some two hundred application engineers from the tube industry to go over tube application problems that come up in the development or production of equipment. These teams, usually made up of three engineers from different companies, go with a Service project engineer to the firm making the equipment and study the circuits for misapplications.

Maintenance Practices

Improved maintenance procedures can many times prevent certain tube failures and also prevent the reporting of nonexistent failures. Of the more than two thousand returned receiving-type tubes collected from ships and from aircraft at the Naval Operating Base and the Naval Air Station, Norfolk, Virginia, and discarded from naval shipboard and aircraft electronic equipment as unsatisfactory or failures, 28.9% were found satisfactory on subsequent testing. These tubes were then made the subject of a critical study by Dr. Bernard Salzberg of the Naval Research Laboratory. It was found that premature removal of tubes as a result of preventive maintenance schedules calls for periodic removal of tubes from equipment and replacement with new tubes. Such preventive maintenance is based on the false idea that used tubes are necessarily poorer than new ones and therefore are more likely to fail. Actually, a used electron tube may be better than a new one. Tube mortality studies by communication companies and by tube manufacturers have repeatedly shown that when a large number of new tubes is put into operation failures occur in significant number during early hours of life. After an initial period, usually lasting for some hundreds of hours, the law of survival is an exponential function of time, so that the number of hours of use which a tube has had is of little value in predicting how much longer it is likely to last. Once a tube has operated successfully

during the initial period, its chances of surviving for a much longer time are usually good.

Some apparatus now in use contains sockets that require selected tubes, which must meet tighter limits for electrical characteristics than are required by JAN or Mil E 1 B specifications to insure proper functioning. In maintenance or trouble-shooting, a new electron tube may be tried as a replacement for a failed tube, and occasionally it will be reported as "weak" or otherwise unsatisfactory. The new tube is then rejected or discarded; but the reason for the difficulty may be that a "selected" tube is required. All tubes which appear unsatisfactory in sockets that require selected tubes should therefore be tried out in other less critical sockets; the chances are that they will be found satisfactory.

Wholesale removal of tubes when equipment trouble is encountered sometimes occurs, especially when tubes of a given type have been reported to be generally troublesome. During emergencies, such wholesale removal of tubes occasionally may be justified, but it should not be followed as a general practice.

Environment Consideration

Tube environment must not be detrimental if failures are to be decreased. An instance of how environment can affect tubes was provided by an experience with the 6AR6 tube in aircraft equipment. It was found that the type 6AR6 had excessive failures in certain sockets. This information led to special tests which disclosed that the two units of the radar equipment in which the 6AR6 was used suffered from excessive heat when operated at high altitudes. The effect of such operation was substantiated by semicontrolled information showing that in these same units there were excessive failures of other tube types which, in other units, had only an average number of failures. Relocation of equipment components containing the 6AR6 tubes to a pressurized region of the aircraft eliminated the excessive 6AR6 tube failure rate.

Redundancy in Design

The theory of probability points to a means of increasing the over-all reliability. This is done by connecting identical systems in parallel and is expressed mathematically as follows:

$$R_t = 1 - (1 - R_p)^n \quad (2)$$

where:

R_t = over-all reliability of the system

R_p = individual reliability of each of the systems in parallel

n = number of systems in parallel

For example, if a component system has a reliability of 80%, and three of these systems are in parallel, the over-all reliability rises from 80 to 99.2%.

Redundancy appears to possess some interesting features, but its disadvantage lies in the increased weight and space required. Also, the need of a decision device in some cases to select which of the several channels is to be used tends partially to nullify the advantage in redundancy. Nevertheless, the existence of an ultimate in reliability for a given system or function must be admitted, at least in the operational sense, so that redundancy may be deemed the only means of achieving a desired reliability after all other means have been tried.

REFERENCE:

1. *Boodman, D. M., "The Reliability of Airborne Radar Equipment," Journal of the Operations Research Society of America, February, 1953.*

Transistor Tester

(Continued from page 11)

of the circuit. By placing an oscilloscope across the cathode follower load, the signal currents and voltages may be observed. This provides a convenient means for checking waveform purity and will show those points at which distortion of the signal occurs. Internally generated noise can also be observed riding on top of the signal waveforms, and much interesting information can be gleaned by varying the d.c. biases and observing the effects on the equivalent circuit parameters and the internally generated noise. By connecting the horizontal scope input terminals through a suitable amplifier to various points in the circuit, the characteristic curves for the transistor may be observed.

This test equipment can be calibrated or checked at any time by inserting a T pad composed of known resistances. The model constructed was found to provide accurate measurements (within 1%) of T pads simulating transistors with collector impedances as high as 5 megohms without sacrificing accuracy in measuring impedances in the 10-1000 ohm range. No complicated circuitry or elaborate switching is necessary in the unit.

INDEX OF ADVERTISERS

NAME	PAGE	NAME	PAGE
Adair Engineering Co., George P.	44	Lampkin Laboratories, Inc.	43
Amperite Co., Inc.	33	McIntosh, Frank H.	44
Ampex Corp.	41	Measurements Corporation	44
Automatic Switch Co.	4	Motorola Communications & Electronics, Inc.	Fourth Cover
Berndt-Bach, Inc.	45	Precision Paper Tube Co.	43
Bird Electronic Corp.	47	Printloid Inc.	44
Boonton Radio Corporation	47	Pye Limited	6, 31
Cannon Electric Co.	19	Radiart Corporation, The	39
Chicago Standard Transformer Corp.	29	Radio Corporation of America	3, 21, 23
Connecticut Telephone & Electric Corp.	37	Rohn Manufacturing Company	44
Eitel-McCullough, Inc.	5, 35	Safety Tower Ladder Co.	40
Electro Motive Mfg. Co., Inc., The	27	Transistor Products, Inc.	38
Electro-Voice	32	U. S. Motors Corporation	26
Gabriel Company, The	44	United Transformer Co.	Second Cover
Hammarlund Manufacturing Co., Inc.	25	Zophar Mills, Inc.	39
Klipsch & Associates	44		

Sulphur Mining

(Continued from page 9)

dropped at Leeville, one a telephone channel and the other a v.h.f. transmitter control. The remaining four go through to Bay Ste. Elaine; three are telephone channels, and the last is used for v.h.f. control. Voice-operated relay panels are used on the v.h.f. circuits.

There are five towers in the system. These are at Venice (200 feet), Port Sulphur (150 feet), Leeville (150 feet), Bay Ste. Elaine (100 feet), and Phoenix (125 feet). At Grande Ecaille, the microwave reflectors and v.h.f. antenna are mounted on a 117-foot water tower; this is done now at Garden Island Bay also, although at the time the photograph showing this installation was taken a temporary 70-foot pole was in use. Elevation at New Orleans is 234 feet. Experience has shown that a higher tower at Leeville would be desirable, and steps are being taken to provide additional height. At present, the tower at Venice is the only one that requires lighting. Since this and the other repeaters at Leeville and Phoenix are normally unattended, automatic lighting controls are installed, with failure notification transmitted to Port Sulphur.

Maintenance Provisions

Standby power sources are installed at the three repeaters, with warning devices that transmit indications of failures to Port Sulphur. Three-kw. Kohler engine-driven generators supply the emergency power; they are equipped with automatic starting and changeover mechanisms.

At Port Sulphur, a power or light failure sets off an alarm and lights an indicator bulb on a 10-channel alarm panel which shows the nature and location of the trouble. Here also, at the maintenance center of the system, is a completely equipped service shop where routine checks of system operation are carried out as well as repair work requiring extensive test equipment. A subcarrier test panel and a ringing generator are invaluable aids in checking modulation levels.

PHOTO CREDITS

PAGE	CREDIT
7, 8, 9.....	Freeport Sulphur Co.
10.....	Tung-Sol Electric Inc.
12, 13 (top).....	Sylvania Elec. Products Inc.
13 (ctr.), 14.....	Western Elec. Co., Inc.
13 (bottom).....	Radio Corp. of America
15.....	Nat. Bureau of Standards
16, 18.....	General Electric Co.

Simplifying HF Power Measurement Model 67 **TERMALINE** DIRECT-READING R-F WATTMETER

30 mc to 500 mc
(to 1000 mc if specified)

50 ohms

Triple Range 0-25 watts
0-100 "
0-500 "

Type N Input Connector
(Adaptor for PL-259 supplied)

● Model 67 is a larger type Wattmeter than the well-known AN-ME-11/U (our Model 611) R-F Wattmeter. Specifically designed for fixed station transmitters to 500 watts output, it may be used nicely on low range for mobile gear. Provided with an aluminum cased, shock-mounted meter, Model 67 is as simple to use as a DC voltmeter. Now in general use throughout the industry, TERMALINE Wattmeters may be depended upon for fast, accurate and repeatable power readings.



NON-RADIATING

... Accuracy—5%

RUGGED CONSTRUCTION

... Size—17" x 9" x 6"

Wght.—30 pounds



BIRD
ELECTRONIC CORP.
1800 EAST 38TH ST., CLEVELAND 14, OHIO
TERMALINE Coaxial Line Instruments

NEELY
ENTERPRISES
Hollywood • San Francisco
Albuquerque
EARL LIPSCOMB
ASSOCIATES
Dallas • Houston

New!
Q STANDARD
measures true Q
to $\pm 3\%$

- Hermetically sealed against humidity effects.
- Inductance accurate to $\pm 1\%$.
- Temperature coefficient data furnished.



TYPE 513-A

SPECIFICATIONS:

INDUCTANCE (L)

Nominal Value: 250 μ h Accuracy: $\pm 1\%$.

DISTRIBUTED CAPACITANCE (Cd)

(When mounted on Type 160-A or 260-A Q-Meter).

Nominal Value: 9.0 puf. Accuracy: $\pm 2\%$.

EFFECTIVE Q (Qe)

(Specified at 0.5, 1.0, and 1.5 mc. and 22°C).

Nominal Value: 180 to 250

Accuracy: $\pm 3\%$.

Here, for the first time, is a Q-Standard which provides an accurately known Q and reactance for precise measurements. It also provides a convenient way to check overall Q-Meter performance.

Write for further information

BOONTON RADIO

BOONTON - N.J. - U.S.A.

Corporation



Bad Weather? Rough Terrain?

You Can Rely on **Motorola® Microwave**
for **NON-STOP**
PERFORMANCE



Motorola Systems Are In and Working—24 Hours a Day— For Power Companies Across the Nation.

Utilities and power companies everywhere have turned to Motorola Microwave for communications that shrug off bad weather and rough terrain. Thousands of miles of multi-channel Motorola Microwave—with hundreds of operating stations—delivering non-stop, 'round-the-clock performance year in and year out.

Motorola Microwave provides simultaneous transmission of numerous (1) voice, (2) telemetering, (3) teleprinting and (4) industrial control signals over one radio frequency carrier. Microwave assures positive control of widely separated, remote system facilities. Get the facts. *Motorola Microwave can cut communications costs, save man-hours and speed operations for you!*



Motorola Communications & Electronics, Inc.
A SUBSIDIARY OF MOTOROLA, INC.
4501 W. Augusta, Chicago 51, Ill. • Rogers Mailestic Electronics Ltd., Toronto, Canada

Motorola Systems Are In and Working for These Companies

Partial list of systems installed and operating.

Arkansas Power and Light Company*
Bonneville Power Administration
Brazos River Electric Transmission Cooperative
Central Illinois Public Service Company
Cleveland Electric Illuminating Company*
Dayton Power and Light Company
Gulf States Utilities Company*
Illinois Power Company
Louisiana Power and Light Company*
Mississippi Power and Light Company*
New Orleans Public Service, Inc.*
Northern Indiana Public Service Company*
Ohio Power Company*
Pacific Power and Light Company
San Antonio Public Service Board
Southern California Edison Company
Texas Electric Company

*Under Construction

*Job-Proven Microwave . . . by the Leaders of
the 2-way Radio Industry*

For full details—write Dept. 2286-REE